

# Engineer's Mini-Notebook

**Basic Semiconductor  
Circuits**

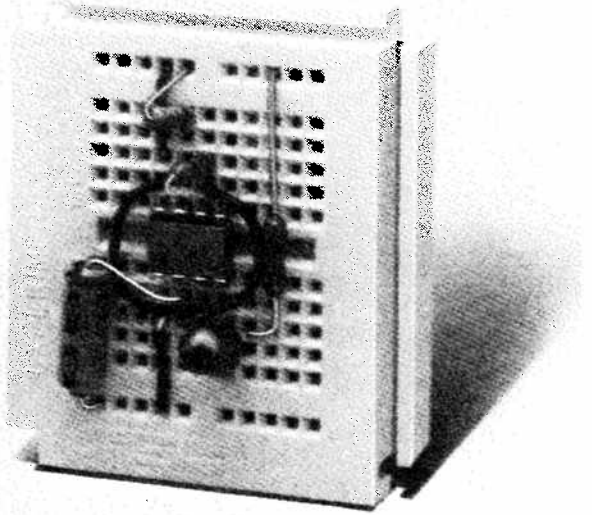

**Forrest M. Mims III**

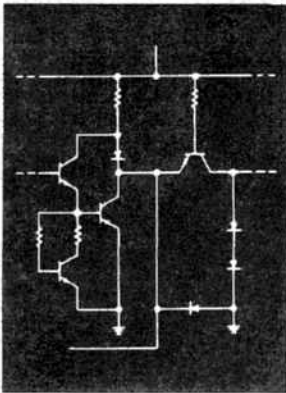

# ENGINEER'S MINI-NOTEBOOK

## BASIC SEMICONDUCTOR CIRCUITS

BY  
FORREST · M. MIMS, III

SIXTH PRINTING-1996

A SILICONCONCEPTS™ BOOK

COPYRIGHT © 1986 BY FORREST M. MIMS, III  
ALL RIGHTS RESERVED

PRINTED IN THE UNITED STATES OF AMERICA

THIS BOOK INCLUDES STANDARD APPLICATION CIRCUITS AND CIRCUITS DESIGNED BY THE AUTHOR. EACH CIRCUIT WAS ASSEMBLED AND TESTED BY THE AUTHOR AS THE BOOK WAS DEVELOPED. AFTER THE BOOK WAS COMPLETED, THE AUTHOR REASSEMBLED EACH CIRCUIT TO CHECK FOR ERRORS. WHILE REASONABLE CARE WAS EXERCISED IN THE PREPARATION OF THIS BOOK, VARIATIONS IN COMPONENT TOLERANCES AND CONSTRUCTION METHODS MAY CAUSE THE RESULTS YOU OBTAIN TO DIFFER FROM THOSE GIVEN HERE. THEREFORE THE AUTHOR AND RADIO SHACK ASSUME NO RESPONSIBILITY FOR THE SUITABILITY OF THIS BOOK'S CONTENTS FOR ANY APPLICATION. SINCE WE HAVE NO CONTROL OVER THE USE TO WHICH THE INFORMATION IN THIS BOOK IS PUT, WE ASSUME NO LIABILITY FOR ANY DAMAGES RESULTING FROM ITS USE. OF COURSE IT IS YOUR RESPONSIBILITY TO DETERMINE IF COMMERCIAL USE, SALE OR MANUFACTURE OF ANY DEVICE THAT INCORPORATES INFORMATION IN THIS BOOK INFRINGES ANY PATENTS, COPYRIGHTS OR OTHER RIGHTS.

DUE TO THE MANY INQUIRIES RECEIVED BY RADIO SHACK AND THE AUTHOR, IT IS NOT POSSIBLE TO PROVIDE PERSONAL RESPONSES TO REQUESTS FOR ADDITIONAL INFORMATION (CUSTOM CIRCUIT DESIGN, TECHNICAL ADVICE, TROUBLESHOOTING ADVICE, ETC.). IF YOU WISH TO LEARN MORE ABOUT ELECTRONICS, SEE OTHER BOOKS IN THIS SERIES AND RADIO SHACK'S "GETTING STARTED IN ELECTRONICS." ALSO, READ MAGAZINES LIKE MODERN ELECTRONICS AND RADIO-ELECTRONICS. THE AUTHOR WRITES A MONTHLY COLUMN, "ELECTRONICS NOTEBOOK," FOR MODERN ELECTRONICS.

# CONTENTS

INTRODUCTION	5
RESISTORS	6-7
HOW TO USE RESISTORS	8-9
CAPACITORS	10-11
HOW TO USE CAPACITORS	12
R-C CIRCUITS	13
DIODES AND RECTIFIERS	14
VOLTAGE DROPPER; REGULATOR	14-15
TRIANGLE-TO-SINE WAVE	15
PEAK-READING VOLTMETER	15
PROTECTION CIRCUITS	16
CLIPPING AND LIMITING CIRCUITS	17
HALF- AND FULL-WAVE RECTIFIERS	18
VOLTAGE MULTIPLIERS	19
DIODE LOGIC GATES	20
DECIMAL-TO-BINARY ENCODER	21
ZENER DIODES	22
VOLTAGE REGULATOR MODEL	22
VOLTAGE INDICATOR	23
VOLTAGE SHIFTER	23
WAVEFORM CLIPPER	23
BIPOLAR TRANSISTORS	24
BASIC SWITCH AND AMPLIFIER	24
RELAY DRIVER; CONTROLLER	25
LED REGULATOR	25
TRANSISTOR AMPLIFIERS; MIXER	26-27
AUDIO OSCILLATOR	28
METRONOME	28
LOGIC PROBE	28
ADJUSTABLE SIREN	29
AUDIO NOISE GENERATOR	29
I-TRANSISTOR OSCILLATOR	30
SWITCH DEBOUNCER	30
	3

MINIATURE RF TRANSMITTER	31
FREQUENCY METER	32
PULSE GENERATOR	33
DC METER AMPLIFIER	33
LIGHT/DARK ACTIVATED FLASHERS	34
HIGH-BRIGHTNESS FLASHER	35
LED TRANSMITTER/RECEIVER	35
RESISTOR-TRANSISTOR LOGIC	36-37
JUNCTION FETS	38
BASIC SWITCH AND AMPLIFIER	38
HI-Z MICROPHONE PREAMPLIFIER	39
HI-Z AUDIO MIXER	39
POWER MOSFETS	40
TIMERS	40
HI-Z SPEAKER AMPLIFIER	41
DUAL LED FLASHER	41
UNIUNCTION TRANSISTORS	42
BASIC UJT OSCILLATOR	42
LOW-VOLTAGE INDICATOR	42
SOUND-EFFECTS GENERATOR	43
1-MINUTE TIMER	43
PIEZOELECTRIC BUZZERS	44
BELL	44
VOLUME CONTROL	44
LOGIC INTERFACES	44
PIEZO-ELEMENT DRIVERS	45
FIXED TONE	45
ADJUSTABLE FREQUENCY	45
SILICON-CONTROLLED RECTIFIERS	46
LATCHING PUSHBUTTON SWITCH	46
LIGHT-ACTIVATED RELAY	46
RELAXATION OSCILLATOR	47
DC MOTOR SPEED CONTROLLER	47
TRIACS	48
TRIAC SWITCH BUFFER	48
LAMP DIMMER	48

# INTRODUCTION

IN THIS ERA OF INTEGRATED CIRCUIT MICROCHIPS, THE SIMPLICITY AND ECONOMY OF CIRCUITS MADE FROM INDIVIDUAL COMPONENTS ARE OFTEN OVERLOOKED. THE CIRCUITS THAT FOLLOW ILLUSTRATE MORE THAN 75 APPLICATIONS FOR SUCH BASIC COMPONENTS AS DIODES, TRANSISTORS, SCRS, AND TRIACS. THESE CIRCUITS ARE PRECEDED BY SECTIONS ON RESISTORS AND CAPACITORS SINCE THESE COMPONENTS ARE AN ESSENTIAL INGREDIENT IN NEARLY ALL SEMICONDUCTOR CIRCUITS.

FOR MORE INFORMATION ABOUT THE COMPONENTS USED IN THE CIRCUITS THAT FOLLOW, SEE "GETTING STARTED IN ELECTRONICS" (RADIO SHACK, 1983). THIS BOOK COVERS BASIC ELECTRONICS AND INCLUDES 100 TESTED CIRCUITS. ALSO, SEE OTHER TITLES IN THE "ENGINEER'S MINI-NOTEBOOK" SERIES.

## CIRCUIT ASSEMBLY TIPS

TEST VERSIONS OF THE CIRCUITS IN THIS BOOK WERE ASSEMBLED ON RADIO SHACK MODULAR BREADBOARD SOCKETS. AFTER ASSEMBLING AND TESTING A CIRCUIT ON A BREADBOARD, YOU CAN ASSEMBLE A PERMANENT VERSION ON A CIRCUIT BOARD AND INSTALL IT IN AN ENCLOSURE. THOUGH EACH CIRCUIT INCLUDES SPECIFIC COMPONENT VALUES, SUBSTITUTIONS ARE USUALLY OK IF VOLTAGE, CURRENT, AND POWER RATINGS ARE OBSERVED. FOR INSTANCE, A 1.2K RESISTOR CAN USUALLY BE SUBSTITUTED FOR A 1K UNIT. A 100K POTENTIOMETER CAN BE USED IN PLACE OF A 50K UNIT. AND MANY NPN TRANSISTORS CAN BE USED FOR THE POPULAR 2N2222. FOR MORE, SEE "GETTING STARTED IN ELECTRONICS."

# RESISTORS

RESISTORS RESIST THE FLOW OF AN ELECTRICAL CURRENT. THE UNIT OF RESISTANCE IS THE OHM ( $\Omega$ ). A POTENTIAL DIFFERENCE OF ONE VOLT WILL FORCE A CURRENT OF ONE AMPERE THROUGH A RESISTANCE OF ONE OHM.

## OHM'S LAW

VOLTAGE (V) IS THE POTENTIAL DIFFERENCE ACROSS A RESISTOR. CURRENT (I) IS THE FLOW OF ELECTRONS THROUGH A RESISTOR. GIVEN ANY TWO VALUES OF RESISTANCE, VOLTAGE, OR CURRENT, THE THIRD VALUE CAN BE CALCULATED FROM OHM'S LAW:

$$V = I \times R \quad I = V/R \quad R = V/I$$

THE POWER DISSIPATED IN A RESISTOR CAN ALSO BE CALCULATED:

$$P = V \times I \quad P = I^2 R$$

THE UNIT OF POWER IS THE WATT. IT IS IMPORTANT TO BE SURE THAT ALL VALUES ARE EXPRESSED PROPERLY WHEN USING OHM'S LAW. FOR EXAMPLE, 65 MILLIVOLTS SHOULD BE EXPRESSED AS 0.065 VOLTS. 470 MILLIWATTS SHOULD BE EXPRESSED AS 0.47 WATTS. A 47K RESISTOR HAS A RESISTANCE OF  $47 \times 1,000$  OR 47,000 OHMS. A 2.2M RESISTOR HAS A RESISTANCE OF  $2.2 \times 1,000,000$  OR 2,200,000 OHMS.

USUALLY YOU MAY USE A RESISTOR WITH A VALUE WITHIN 10-20% OF THE REQUIRED VALUE. ALWAYS USE RESISTORS HAVING THE PROPER POWER RATING.



## RESISTORS IN SERIES



$$\text{TOTAL RESISTANCE } (R_T) = R_1 + R_2$$

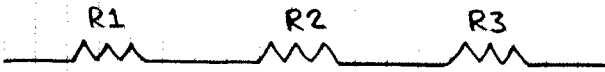

$$\text{TOTAL RESISTANCE } (R_T) = R_1 + R_2 + R_3$$

## RESISTORS IN PARALLEL

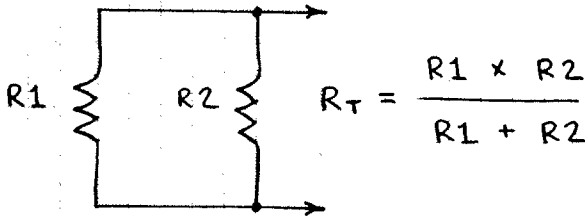

$$R_T = \frac{R_1 \times R_2}{R_1 + R_2}$$

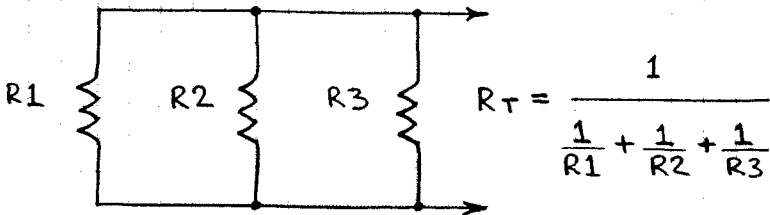

$$R_T = \frac{1}{\frac{1}{R_1} + \frac{1}{R_2} + \frac{1}{R_3}}$$

IF  $R_1 = R_2 = R_3$ , THEN  $R_T = R_1 / 3$ .

## RESISTORS IN SERIES/PARALLEL

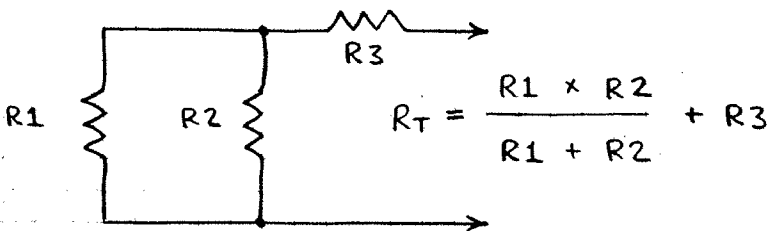

$$R_T = \frac{R_1 \times R_2}{R_1 + R_2} + R_3$$

# HOW TO USE RESISTORS

## CURRENT LIMITING

A RESISTOR CAN BE PLACED IN SERIES WITH A LAMP, LED, SPEAKER, TRANSISTOR, OR OTHER COMPONENT TO REDUCE THE FLOW OF CURRENT THROUGH THE DEVICE. FOR EXAMPLE:

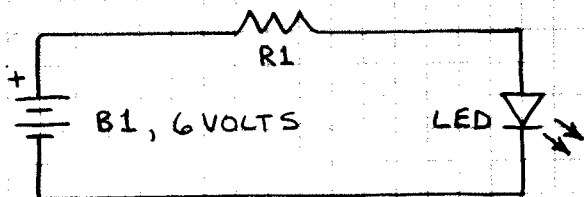

OHM'S LAW CAN BE USED TO CALCULATE THE CURRENT THROUGH THE LED FOR A RANGE OF STANDARD RESISTANCE VALUES. THE FORMULA FOR CURRENT IS  $I = V/R$ . AN LED DOES NOT BEGIN TO CONDUCT UNTIL THE FORWARD VOLTAGE IS ABOUT 1.7 VOLTS (RED LED). THEREFORE, THE FORMULA FOR CURRENT IS  $I = (6 - 1.7)/R$ .

R1 (OHMS)	LED CURRENT (AMPS)
100	.043
150	.029
220	.020
270	.016
330	.013

## VOLTAGE DIVISION

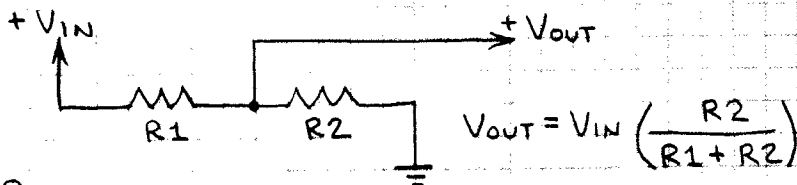

# WHEATSTONE BRIDGE

THE WHEATSTONE BRIDGE PERMITS VERY ACCURATE MEASUREMENTS OF RESISTANCE. HERE IS THE BASIC CIRCUIT:

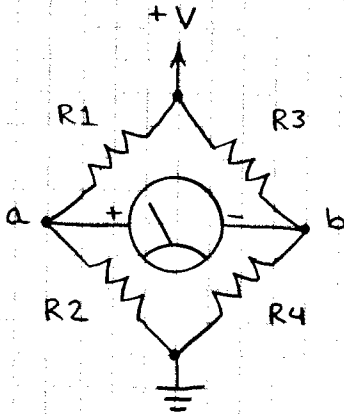

R1-R2 AND R3-R4 FORM TWO VOLTAGE DIVIDERS. WHEN THE VOLTAGE AT a EQUALS THE VOLTAGE AT b, THE METER INDICATES NO VOLTAGE AND THE BRIDGE IS SAID TO BE BALANCED. WHEN THIS OCCURS, THEN:  
 $R1/R3 = R2/R4$ .

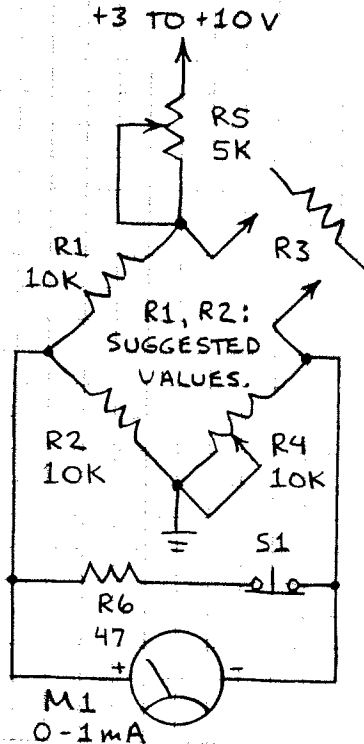

THE BRIDGE SHOWN HERE PERMITS THE ACCURATE MEASUREMENT OF AN UNKNOWN RESISTANCE (R3). R1 AND R2 SHOULD BE PRECISION (±1%) RESISTORS. R4 IS A POTENTIOMETER WITH A CALIBRATED DIAL. R5 IS USED TO REGULATE THE CURRENT FROM THE POWER SUPPLY. R6 AND S1 FORM A SHUNT THAT PROTECTS M1. ADJUST R4 UNTIL M1=0. PRESS S1 AND REPEAT.  $R3 = R4$ . IF  $R1 \neq R2$ , THEN  $R3 = (R1 \times R4) / R2$ .

# CAPACITORS

CAPACITORS STORE AN ELECTRICAL CHARGE. THE UNIT OF CAPACITANCE IS THE FARAD. A 1-FARAD CAPACITOR CONNECTED TO A 1-VOLT SUPPLY WILL STORE A CHARGE OF  $6.28 \times 10^{18}$  ELECTRONS. MOST CAPACITORS HAVE CONSIDERABLY LESS CAPACITY. VALUES COMMONLY RANGE FROM A FEW PICOFARADS ( $10^{-12}$  FARAD) TO A FEW THOUSAND MICROFARADS ( $10^{-6}$  FARAD).

- 1 FARAD = 1 F
- 1 MICROFARAD =  $1 \mu\text{F} = 10^{-6}$  F
- 1 NANOFARAD =  $1 \text{nF} = 10^{-9}$  F
- 1 PICO FARAD =  $1 \text{pF} = 10^{-12}$  F

A CAPACITOR CAN BE CHARGED ALMOST INSTANTLY BY CONNECTING ITS LEADS DIRECTLY ACROSS A POWER SUPPLY. THE CHARGING TIME CAN BE INCREASED BY INSERTING A RESISTOR BETWEEN THE SUPPLY AND THE CAPACITOR.

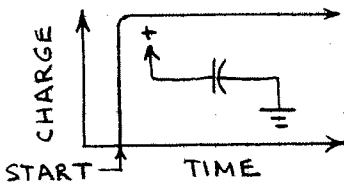

DIRECT CHARGE

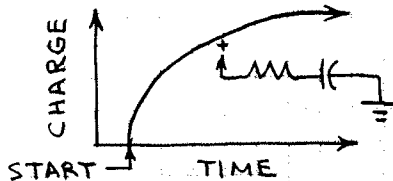

RESISTIVE CHARGE

A CHARGED CAPACITOR WILL GRADUALLY LOSE ITS CHARGE THROUGH LEAKAGE. THE DISCHARGE TIME CAN BE REDUCED BY CONNECTING A RESISTOR ACROSS THE CAPACITOR'S TWO LEADS:

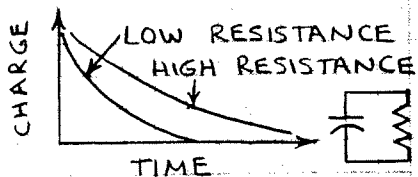

# CAPACITORS IN SERIES

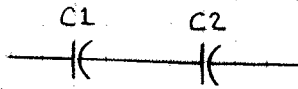

$$\text{TOTAL CAPACITANCE } (C_T) = \frac{C_1 \times C_2}{C_1 + C_2}$$

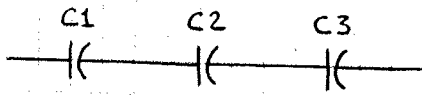

$$\text{TOTAL CAPACITANCE } (C_T) = \frac{1}{\frac{1}{C_1} + \frac{1}{C_2} + \frac{1}{C_3}}$$

# CAPACITORS IN PARALLEL

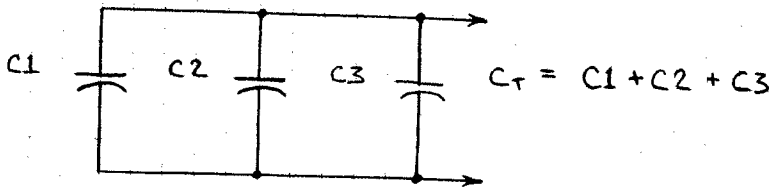
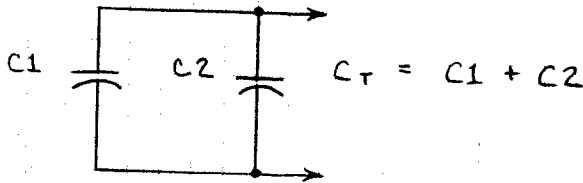

## WARNING!

MOST CAPACITORS CAN RETAIN A CHARGE FOR A CONSIDERABLE TIME AFTER THE CHARGING SUPPLY HAS BEEN SWITCHED OFF. THEREFORE USE CAUTION WHEN WORKING WITH CAPACITORS. A LARGE ELECTROLYTIC CAPACITOR CHARGED TO ONLY 5 TO 10 VOLTS CAN MELT THE TIP OF A SCREWDRIVER SHORTED ACROSS ITS LEADS! HIGH-VOLTAGE CAPACITORS IN TV SETS AND PHOTOFLASH UNITS CAN STORE A LETHAL CHARGE!

# HOW TO USE CAPACITORS

## SIGNAL FILTERING

A SINGLE CAPACITOR CAN DIVERT AN UNWANTED SIGNAL TO GROUND:

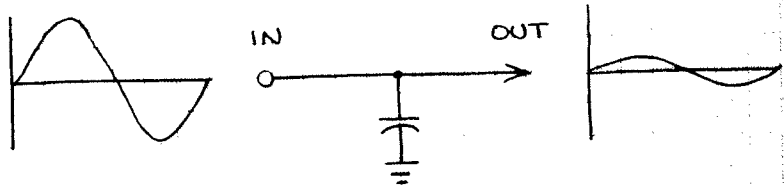

A SINGLE CAPACITOR CAN REMOVE AN UNWANTED DC COMPONENT FROM A FLUCTUATING SIGNAL:

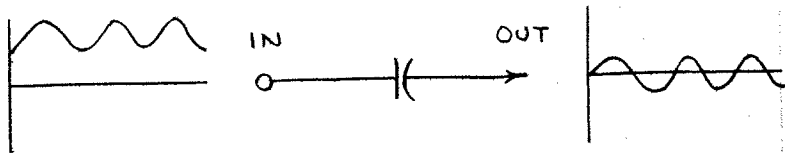

## POWER SUPPLY FILTERING

A LARGE CAPACITOR WILL SMOOTH THE PULSATING VOLTAGE FROM A POWER SUPPLY INTO STEADY DIRECT CURRENT:

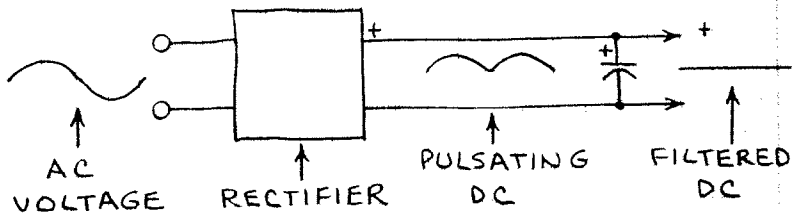

## SPIKE AND NOISE SUPPRESSION

A  $0.1 \mu\text{F}$  CAPACITOR ACROSS THE POWER SUPPLY PINS OF A LOGIC CHIP WILL HELP SUPPRESS FALSE TRIGGERING CAUSED BY BRIEF POWER SUPPLY NOISE SPIKES.

# RESISTOR-CAPACITOR CIRCUITS

AMONG THE MOST IMPORTANT OF ALL CIRCUITS ARE THE BASIC RESISTOR-CAPACITOR (RC) CIRCUITS:

## INTEGRATOR

THE INTEGRATOR IS AN RC CIRCUIT THAT TRANSFORMS AN INCOMING SQUARE WAVE INTO A TRIANGLE WAVE:

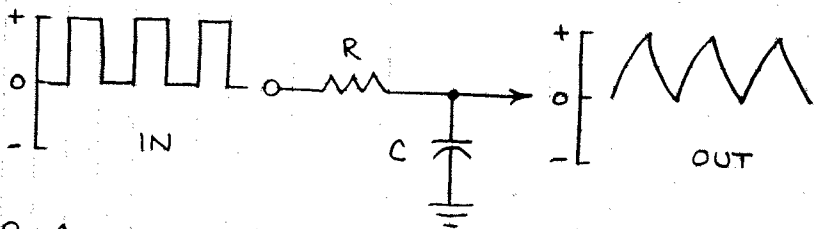

$R \times C$  IS THE TIME CONSTANT OF THE CIRCUIT.  $RC$  MUST BE AT LEAST 10 TIMES THE PERIOD OF THE INPUT SIGNAL. IF NOT, THE AMPLITUDE OF THE OUTPUT SIGNAL WILL BE REDUCED. THE CIRCUIT WILL THEN BE A LOW-PASS FILTER THAT BLOCKS HIGH FREQUENCIES.

## DIFFERENTIATOR

THE DIFFERENTIATOR IS AN RC CIRCUIT THAT TRANSFORMS AN INCOMING SQUARE WAVE INTO A PULSED OR SPIKED WAVEFORM:

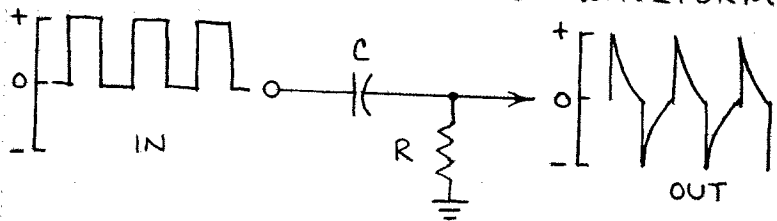

THE RC TIME CONSTANT SHOULD BE  $1/10$  (OR LESS) OF THE DURATION OF THE INCOMING PULSES. DIFFERENTIATORS ARE OFTEN USED TO CREATE TRIGGER PULSES.

# REVERSE-POLARITY PROTECTOR

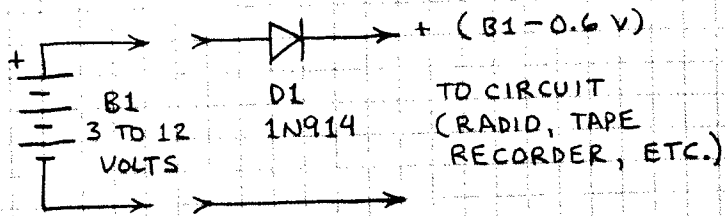

DIODE PROTECTS CIRCUIT IF BATTERY IS INSTALLED WITH REVERSED POLARITY.

# TRANSIENT PROTECTOR

WHEN THE CURRENT FLOWING THROUGH AN INDUCTOR IS SUDDENLY SWITCHED OFF, THE COLLAPSING MAGNETIC FIELD WILL GENERATE A HIGH VOLTAGE IN THE INDUCTOR'S COILS. THIS VOLTAGE SPIKE MAY HAVE AN AMPLITUDE OF HUNDREDS OR EVEN THOUSANDS OF VOLTS. A DIODE CAN PROTECT THE CIRCUIT TO WHICH THE INDUCTOR IS CONNECTED BY PROVIDING A SHORT CIRCUIT FOR THE HIGH VOLTAGE SPIKE. FOR EXAMPLE:

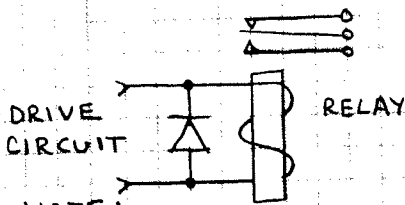

NOTE:  
D1 INEFFECTIVE DURING TURN-ON TIME.

WHEN THE DRIVE CIRCUIT SWITCHES THE RELAY OFF, A HIGH-VOLTAGE SPIKE IS GENERATED IN THE RELAY'S COIL. D1 SHORT CIRCUITS THIS SPIKE.

# METER PROTECTOR

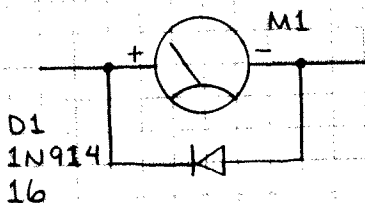

CONNECT A DIODE ACROSS THE TERMINALS OF A METER TO PROVIDE REVERSE CURRENT PROTECTION.



# ADJUSTABLE WAVEFORM CLIPPER

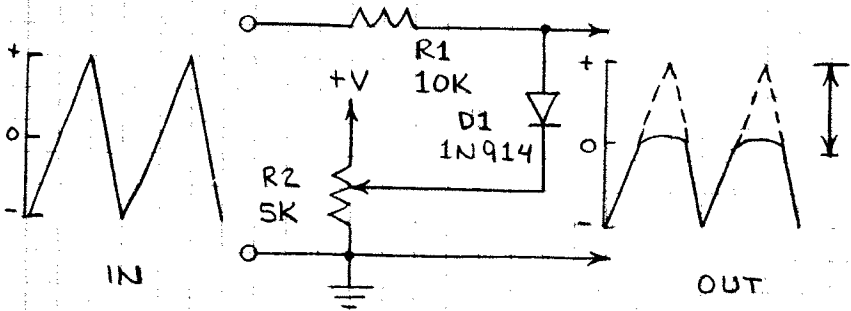

ADJUST R2 TO CONTROL CLIPPING AMPLITUDE. +V SHOULD BE A VOLT OR SO HIGHER THAN PEAK INPUT VOLTAGE.

# ADJUSTABLE ATTENUATOR

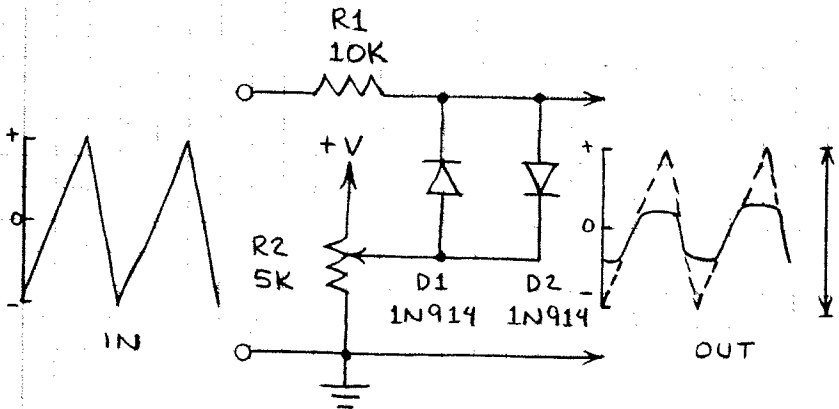

THIS IS A BIPOLARITY (+/-) VERSION OF THE ADJUSTABLE CLIPPER.

# AUDIO LIMITER

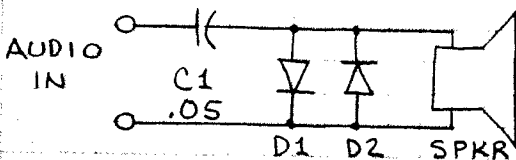

USE TO LIMIT NOISE, POPS, AND STATIC.

D1, D2 = 1N914

# HALF-WAVE RECTIFIER

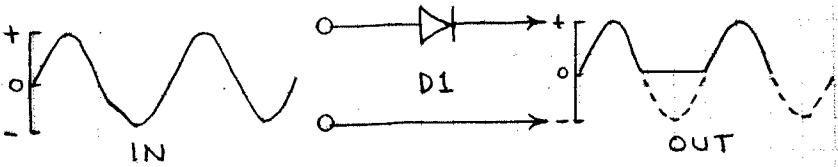

D1 IS ANY DIODE RATED FOR THE INPUT VOLTAGE. THIS CIRCUIT IS USED TO TRANSFORM AN AC WAVE INTO PULSATING DC AND TO DETECT MODULATED RADIO SIGNALS.

# DUAL HALF-WAVE RECTIFIER

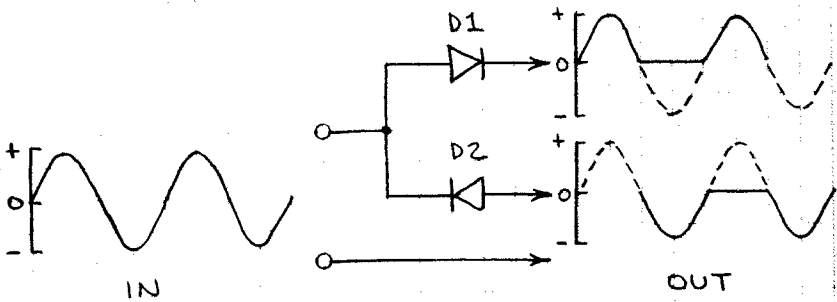

THIS CIRCUIT TRANSFORMS BOTH HALVES OF AN AC WAVE INTO PULSATING DC.

# FULL-WAVE RECTIFIER

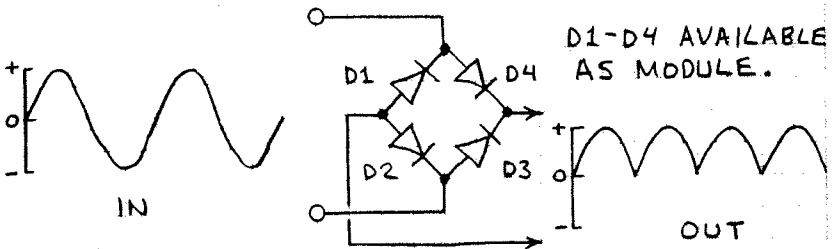

ALSO CALLED A BRIDGE RECTIFIER. USED TO TRANSFORM BOTH HALVES OF AC WAVE TO DC.

# CASCADE VOLTAGE DOUBLER

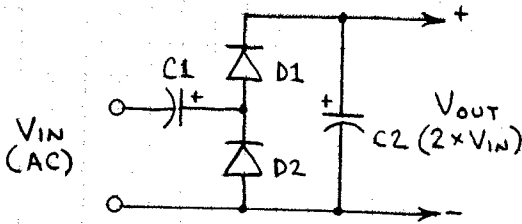

COMPONENTS SHOULD BE RATED AT  $2 \times V_{IN}$ . USE LARGE VALUE CAPACITORS TO REDUCE RIPPLE.

# BRIDGE VOLTAGE DOUBLER

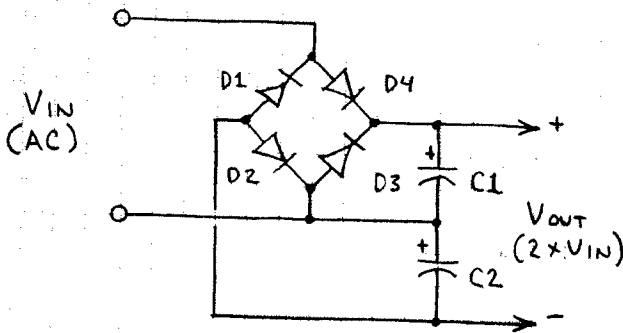

COMPONENTS SHOULD BE RATED AT  $2 \times V_{IN}$ . OK TO USE BRIDGE MODULE FOR D1, D2, D3, AND D4.

# VOLTAGE QUADRUPLER

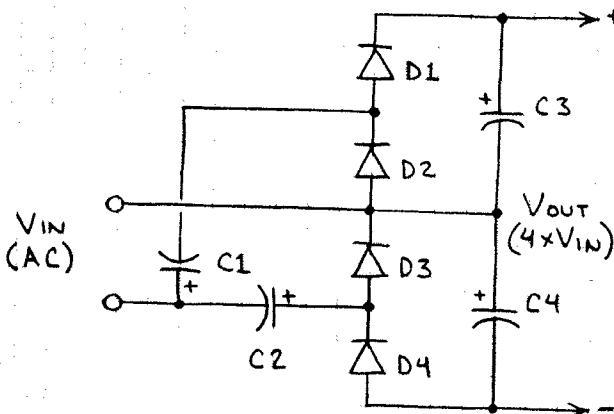

COMPONENTS SHOULD BE RATED AT  $2 \times V_{IN}$ . USE LARGE VALUE CAPACITORS TO REDUCE RIPPLE.

**CAUTION:** VOLTAGE MULTIPLICATION CIRCUITS CAN PRODUCE HIGH VOLTAGES. USE CARE!

# DIODE LOGIC GATES

THESE SIMPLE LOGIC CIRCUITS CAN BE USED TO TEACH BASICS OF DIGITAL LOGIC AND IN PRACTICAL APPLICATIONS.

## OR GATE

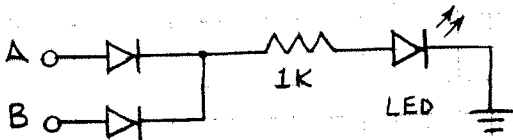

0 = GROUND  
1 = +6V

A	B	LED
0	0	OFF
0	1	ON
1	0	ON
1	1	ON

## NOR GATE

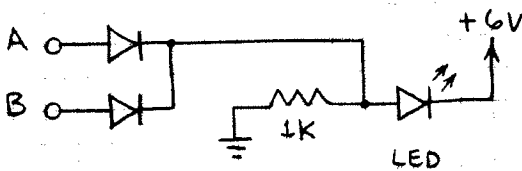

A	B	LED
0	0	ON
0	1	OFF
1	0	OFF
1	1	OFF

## AND GATE

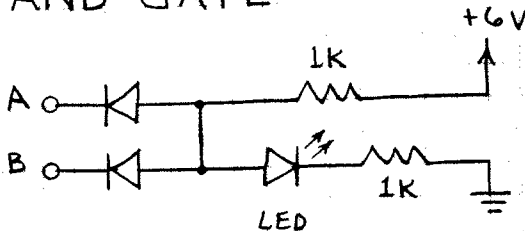

A	B	LED
0	0	OFF
0	1	OFF
1	0	OFF
1	1	ON

## NAND GATE

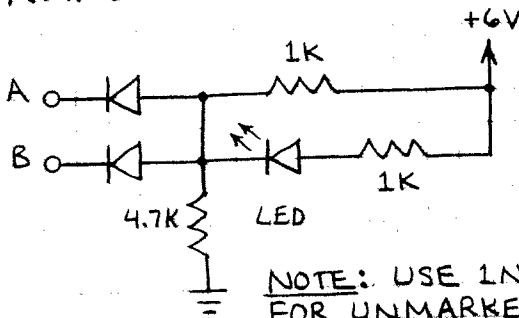

A	B	LED
0	0	ON
0	1	ON
1	0	ON
1	1	OFF

NOTE: USE 1N914 (OR SIMILAR) FOR UNMARKED INPUT DIODES.

# DECIMAL-TO-BINARY ENCODER

THIS CIRCUIT IS A PROGRAMMABLE READ-ONLY MEMORY (PROM). USE 1N914 DIODES.

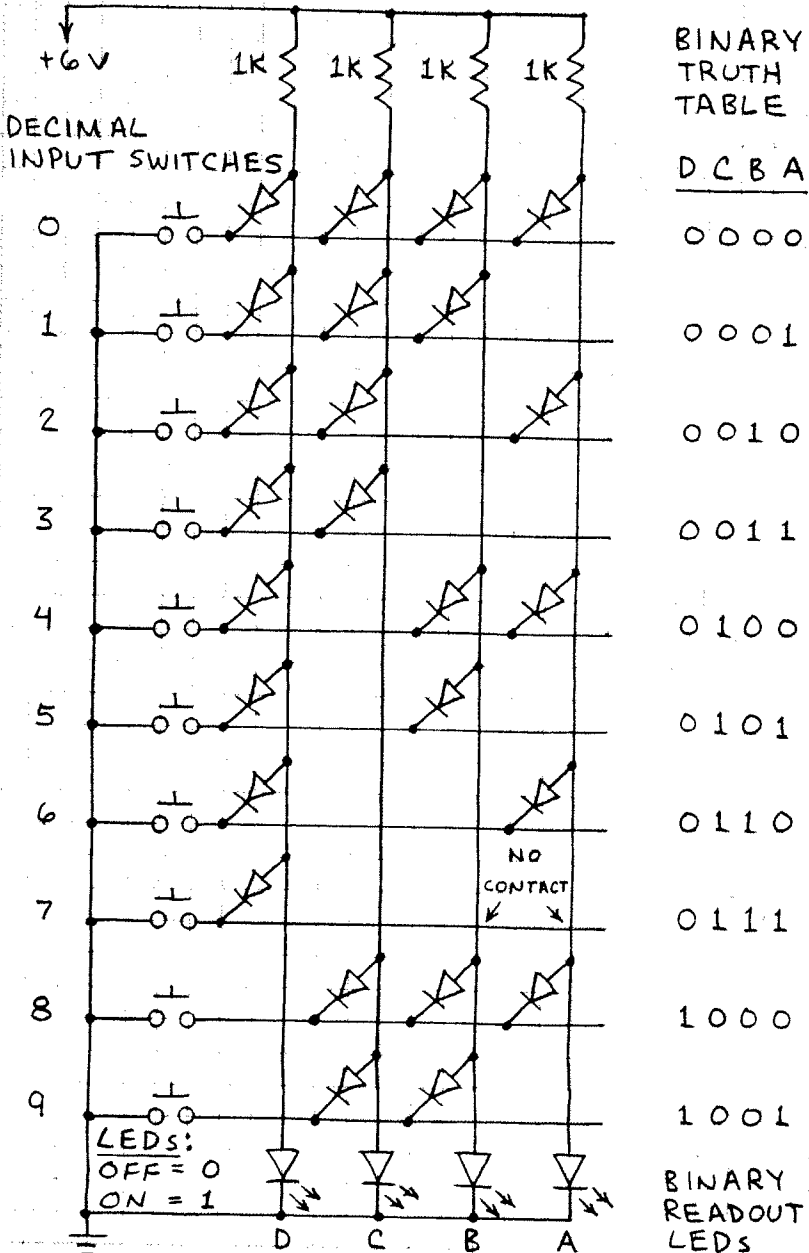

BINARY TRUTH TABLE

D C B A

0 0 0 0

0 0 0 1

0 0 1 0

0 0 1 1

0 1 0 0

0 1 0 1

0 1 1 0

0 1 1 1

1 0 0 0

1 0 0 1

BINARY READOUT LEDS

# ZENER DIODES

NORMALLY A CURRENT DOES NOT FLOW THROUGH A DIODE CONNECTED IN THE REVERSE DIRECTION. THE ZENER DIODE IS DESIGNED SPECIFICALLY TO BEGIN CONDUCTING IN THE REVERSE DIRECTION WHEN THE REVERSE VOLTAGE EXCEEDS A THRESHOLD VALUE (THE BREAKDOWN VOLTAGE). THEREFORE THE ZENER DIODE IS A VOLTAGE-SENSITIVE SWITCH. THIS GRAPH SUMS UP ZENER DIODE OPERATION:

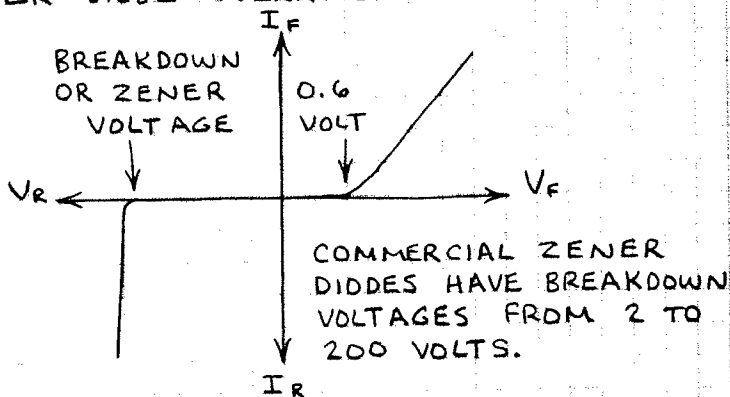

## VOLTAGE REGULATOR MODEL

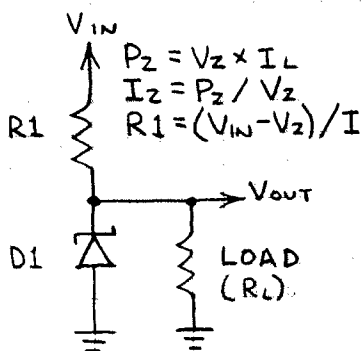

$$P_z = V_z \times I_L$$

$$I_z = P_z / V_z$$

$$R_1 = (V_{IN} - V_z) / I$$

$V_{IN}$  MUST BE AT LEAST 1 VOLT ABOVE  $V_{OUT}$ .  $I_L$  CAN VARY FROM 0mA TO MAXIMUM PLANNED VALUE. D1 AND R1 MUST HAVE PROPER POWER RATING (USE OHM'S LAW).

$I_L$  = MAXIMUM LOAD I  
 $I_z$  = MAXIMUM ZENER I  
 $I$  = R1 CURRENT  
 $V_z$  = ZENER VOLTAGE  
 $P_z$  = ZENER CURRENT.

SAMPLE REGULATOR:

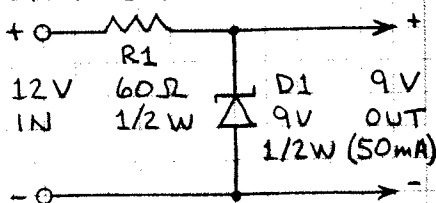

# VOLTAGE INDICATOR

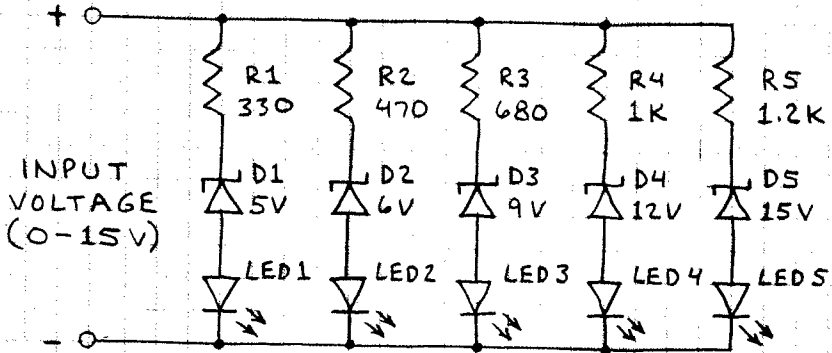

LEDs GLOW IN SEQUENCE AS INPUT VOLTAGE RISES. OK TO USE DIFFERENT ZENERS SO LONG AS SERIES RESISTOR LIMITS CURRENT THROUGH LED TO SAFE VALUE.

# VOLTAGE SHIFTER

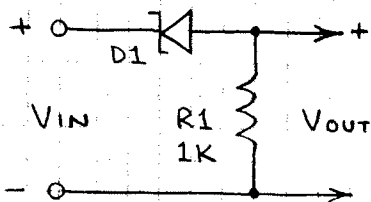

V <sub>IN</sub>	V <sub>OUT</sub>
5	0
6	.36
9	3.17
12	6.37
15	9.27

# WAVEFORM CLIPPERS

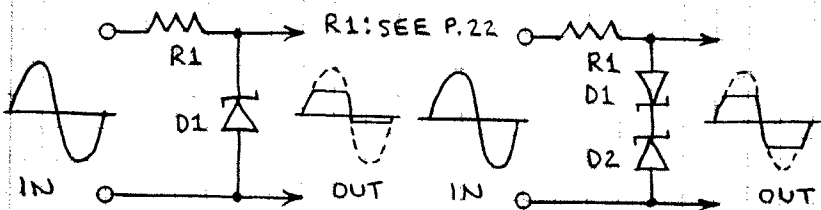

USE TO REDUCE LEVEL OF INCOMING SIGNAL. ALSO CONVERTS SINE WAVE TO NEAR SQUARE WAVE.

CLIPS BOTH HALVES OF WAVE (EQUALLY WHEN D1=D2). USE AS POP FILTER FOR SPEAKERS AND PHONES.

# BIPOLAR TRANSISTORS

A BIPOLAR TRANSISTOR IS A 3-TERMINAL SEMICONDUCTOR DEVICE IN WHICH A SMALL CURRENT AT ONE TERMINAL CAN CONTROL A MUCH LARGER CURRENT FLOWING BETWEEN THE SECOND AND THIRD TERMINAL. THIS MEANS TRANSISTORS CAN FUNCTION AS BOTH AMPLIFIERS AND SWITCHES. BIPOLAR TRANSISTORS ARE CLASSIFIED AS NPN OR PNP ACCORDING TO THE DOPING CONTAINED IN THEIR THREE REGIONS.

## BASIC TRANSISTOR SWITCHES

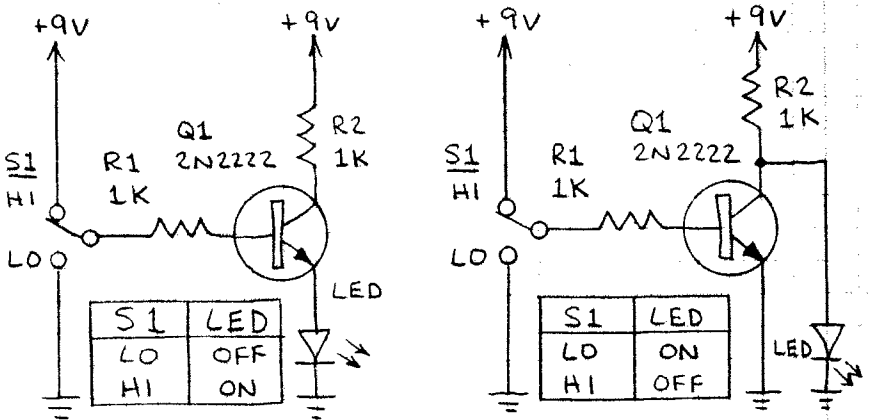

## BASIC TRANSISTOR AMPLIFIER

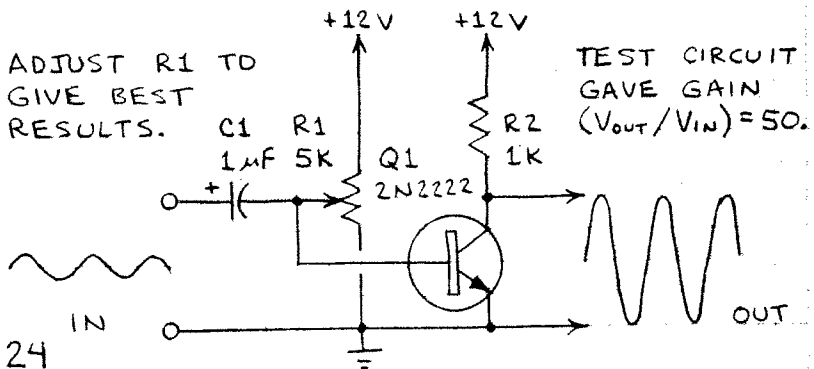



# RELAY DRIVER

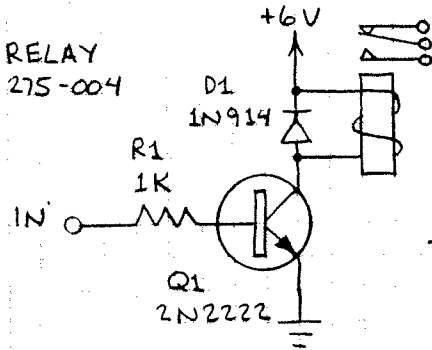

RELAY 275-004  
RELAY PULLS IN WHEN INPUT IS POSITIVE.  
APPLICATION:

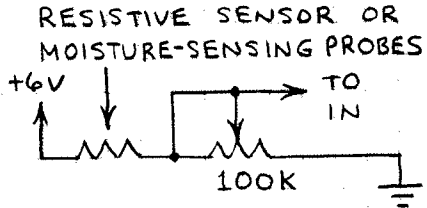

# RELAY CONTROLLER

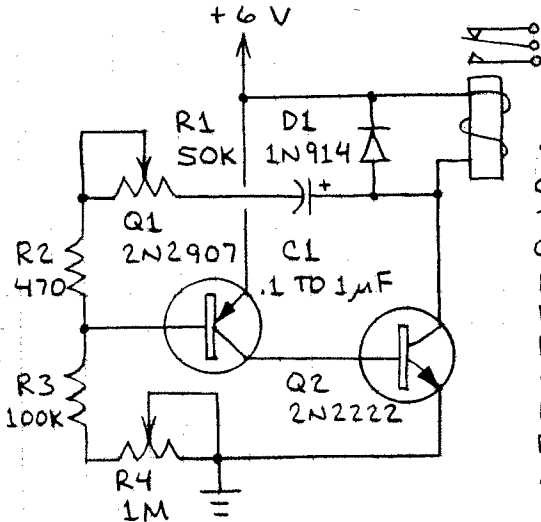

RELAY 275-004  
SUPPLIES SEQUENCE OF DRIVE PULSES TO RELAY. R1 AND C1 CONTROL PULSE RATE AND TIME RELAY IS CLOSED PER PULSE. R4 CONTROLS PULSE RATE. USE TO FLASH LAMPS AND CONTROL MOTORS.

# LED REGULATOR

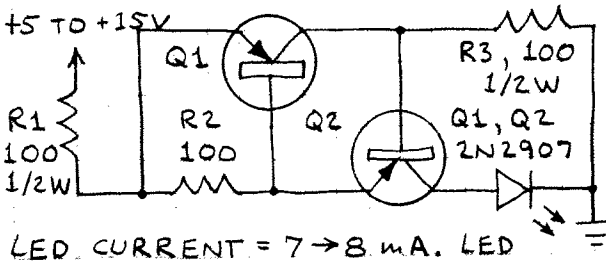

SUPPLIES CONSTANT CURRENT TO LED AS SUPPLY VOLTAGE CHANGES.

LED CURRENT = 7 → 8 mA. LED

# 3-VOLT SPEAKER AMPLIFIER

USE TO GIVE LOW-POWER SPEAKER TO RADIOS AND TAPE PLAYERS WITHOUT SPEAKERS.

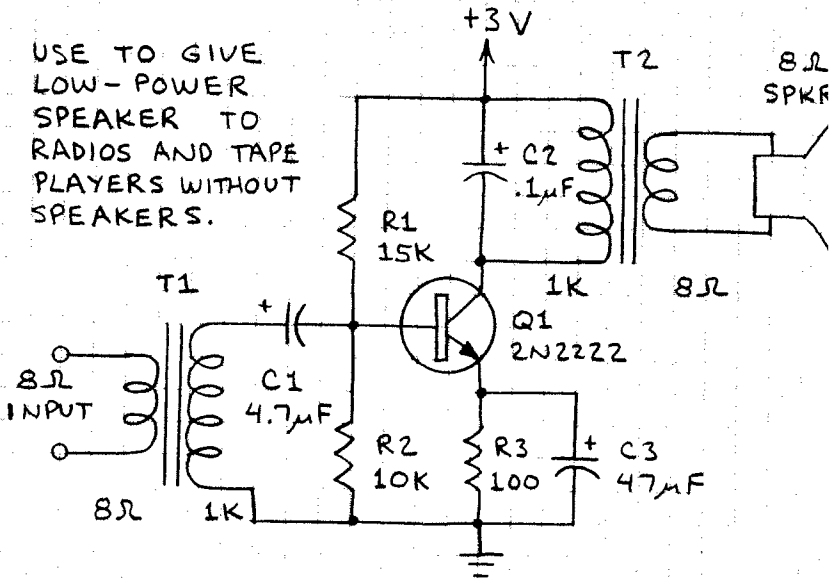

# 2-STAGE SPEAKER AMPLIFIER

THIS CIRCUIT REQUIRES NO INPUT TRANSFORMER.

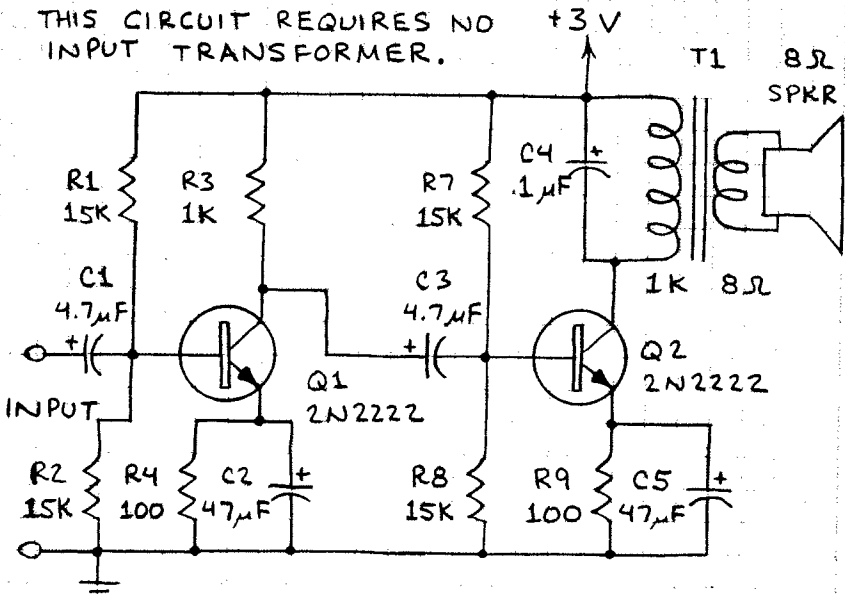

USE TO GIVE LOW-POWER SPEAKER TO RADIOS AND TAPE PLAYERS WITHOUT SPEAKERS.

# MICROPHONE PREAMPLIFIER

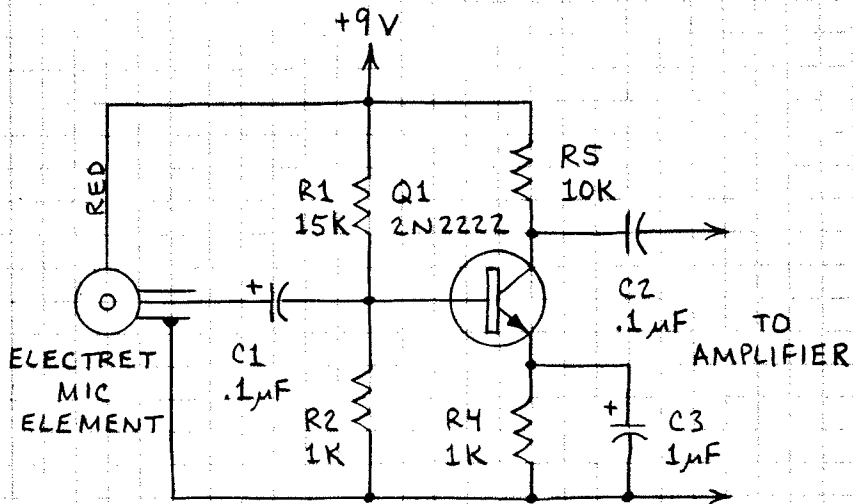

USE WITH TAPE RECORDERS, PUBLIC ADDRESS SYSTEMS AND PORTABLE AMPLIFIERS.

# AUDIO MIXER

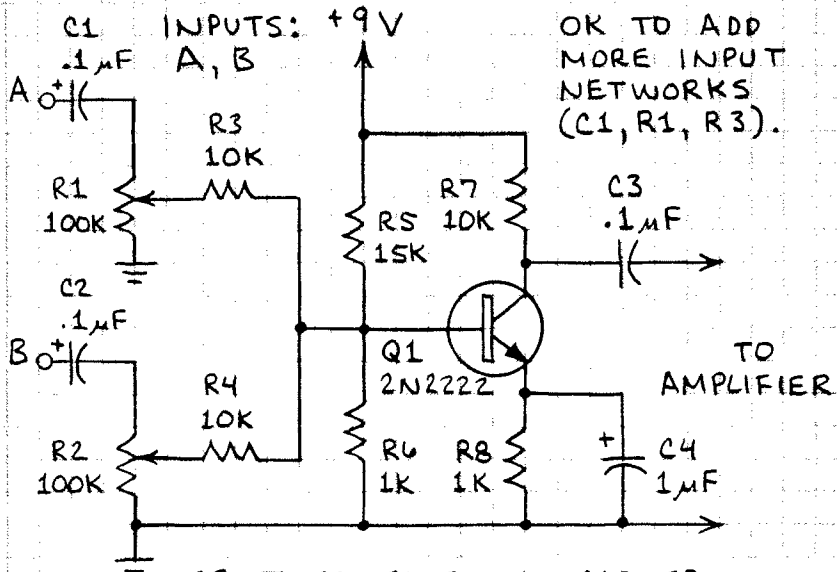

USE TO COMBINE SIGNALS FROM TWO (OR MORE) AMPLIFIERS, MICROPHONES, ETC.

# AUDIO OSCILLATOR

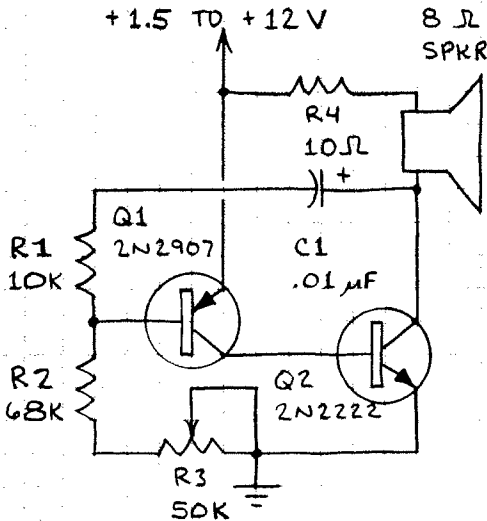

WITH VALUES SHOWN, THIS CIRCUIT CREATES AN AUDIO TONE OF UP TO SEVERAL THOUSAND HERTZ. THE FREQUENCY IS CONTROLLED BY R3. OK TO USE MANY DIFFERENT TRANSISTORS FOR Q1 AND Q2. FOR VERY SLOW FREQUENCIES, INCREASE C1.

# METRONOME

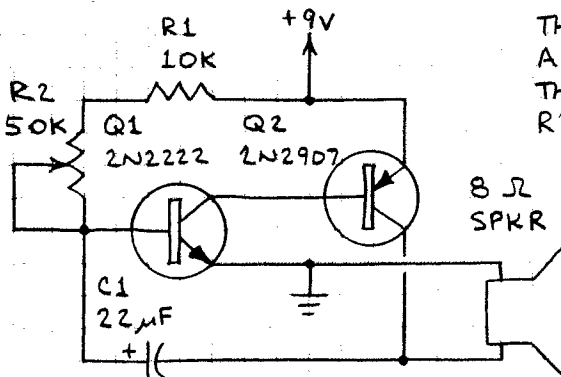

THIS CIRCUIT IS A VARIATION OF THE CIRCUIT ABOVE. R2 CONTROLS THE "CLICK" RATE. OK TO USE VARIOUS TRANSISTORS FOR Q1 AND Q2.

# LOGIC PROBE

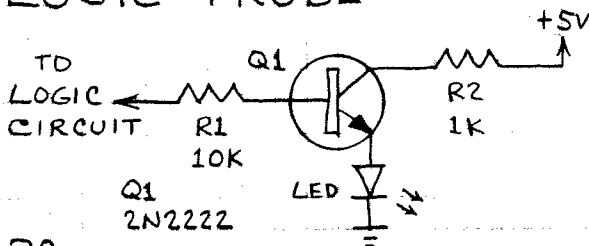

LOGIC IN	LED
LO	OFF
HI	ON

# ADJUSTABLE SIREN

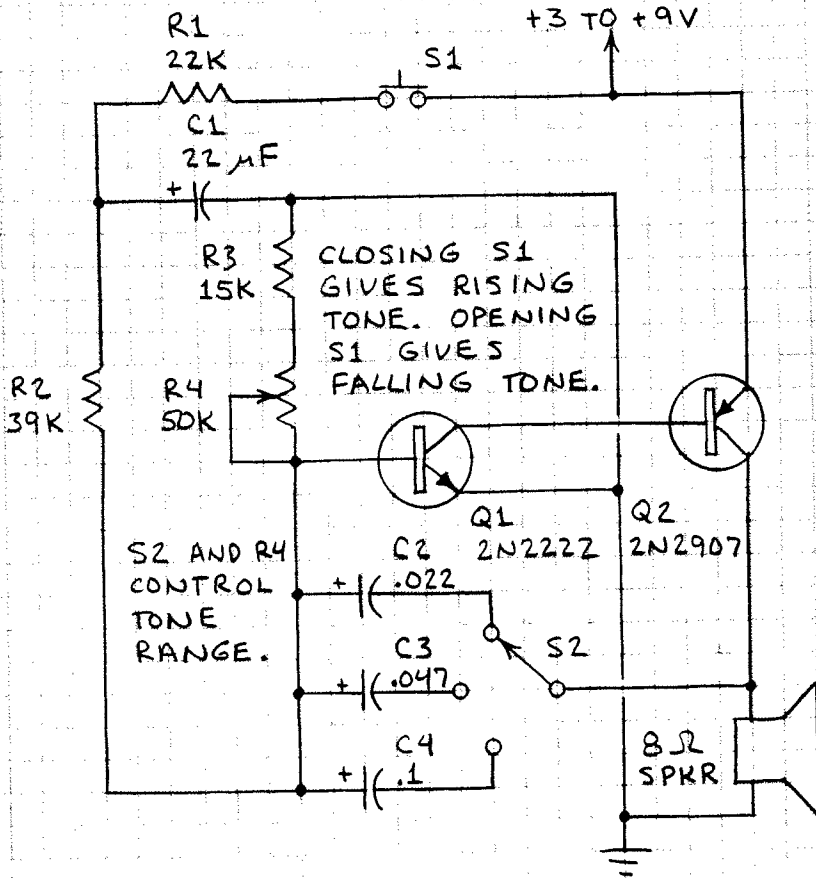

# AUDIO NOISE GENERATOR

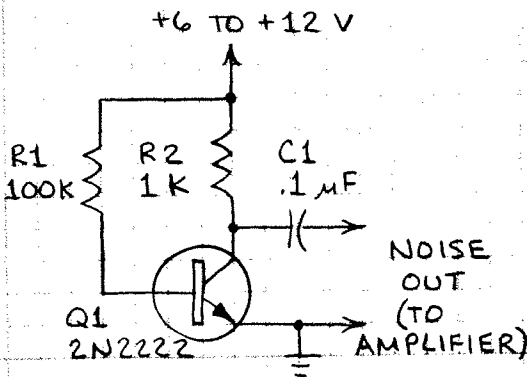

USE TO CREATE FUZZ SOUND AND OTHER SPECIAL EFFECTS OR AS NOISE SOURCE FOR TESTING ROOM ACOUSTICS WITH SOUND METER.

# 1-TRANSISTOR OSCILLATOR

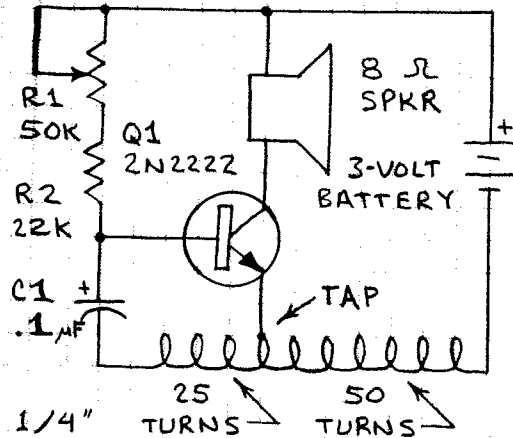

THIS IS A SIMPLIFIED HARTLEY OSCILLATOR. ADJUST R1 TO CHANGE TONE FREQUENCY. CONSUMES ONLY 100-200 MICROAMPERES.

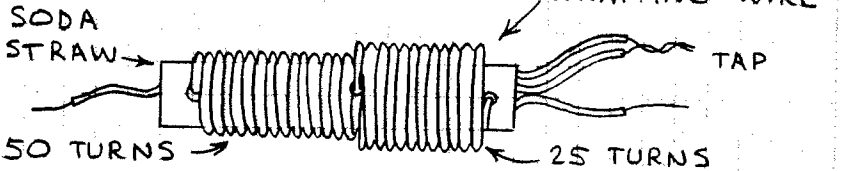

COIL: PUNCH TWO SMALL HOLES 1-1/8" APART IN STRAW. INSERT WIRE IN FIRST HOLE, WIND 50 TURNS, INSERT WIRE LOOP IN SECOND HOLE, AND WIND BACK 25 TURNS. PUNCH HOLE THROUGH FIRST WINDING AND INSERT END OF WIRE. TAP: CUT LOOP AND TWIST EXPOSED WIRES.

# SWITCH DEBOUNCER

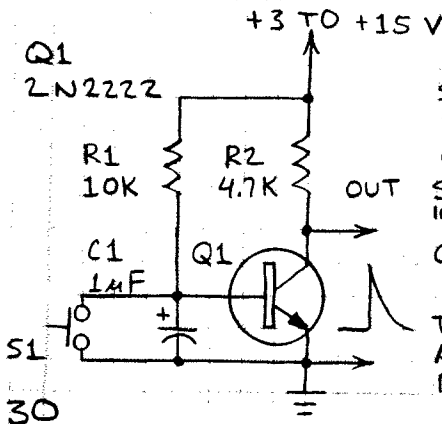

SUPPLIES SINGLE TRIGGER PULSE TO LOGIC CIRCUITS. SWITCH ALONE WILL "BOUNCE" WHEN CLOSED, CAUSING FALSE PULSES.

TO LOCK OUT S1 FOR A SECOND AFTER A PULSE, LET C1=220µF.

# MINIATURE RF TRANSMITTER

THIS CIRCUIT IS PATTERNED AFTER A PILL-SIZED BIOTELEMETRY TRANSMITTER FIRST DEVELOPED BY DR. R. STEWART MACKAY AND OTHER MEDICAL RESEARCHERS IN THE LATE 1950'S. THIS TRANSMITTER REMAINS ONE OF THE SMALLEST EVER DEVELOPED.

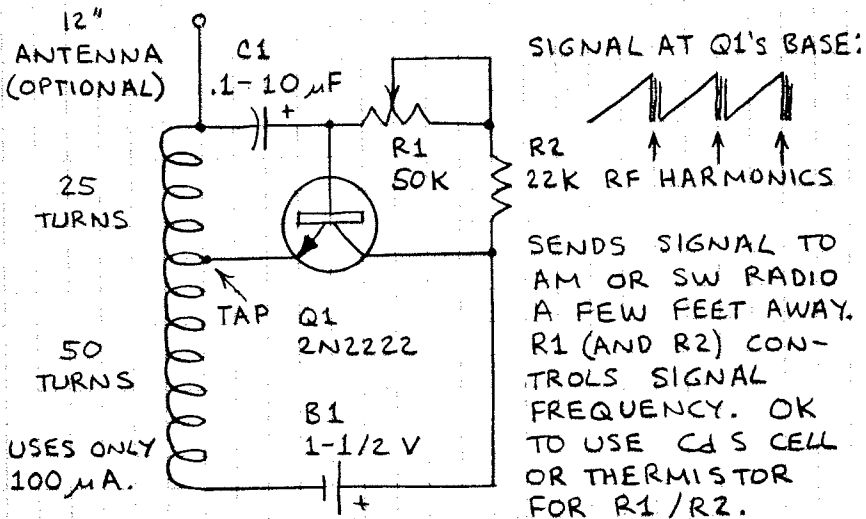

COIL: USE THE COIL SHOWN ON THE FACING PAGE OR MAKE A MUCH SMALLER VERSION WITH A 1/2" LENGTH OF SODA STRAW AND NO. 30 MAGNET WIRE. BURN THE VARNISH FROM THE LAST 1/4" OF THE COIL'S LEADS (USE A MATCH). THEN LIGHTLY BUFF THE CHARRED VARNISH WITH FINE SAND PAPER.

B1: USE A PENLIGHT CELL OR A MERCURY OR SILVER OXIDE BUTTON CELL. WARNING: NEVER ATTEMPT TO SOLDER LEADS TO MINIATURE POWER CELLS. THEY WILL EXPLODE.

C1: 0.1  $\mu$ F GIVES AUDIO TONE; 10  $\mu$ F GIVES AUDIBLE CLICKS. INSERT FERRITE CORE OR STEEL NAIL IN COIL TO ALTER THE SIGNAL. USE MINIATURE ELECTROLYTIC CAPACITOR.

# FREQUENCY METER

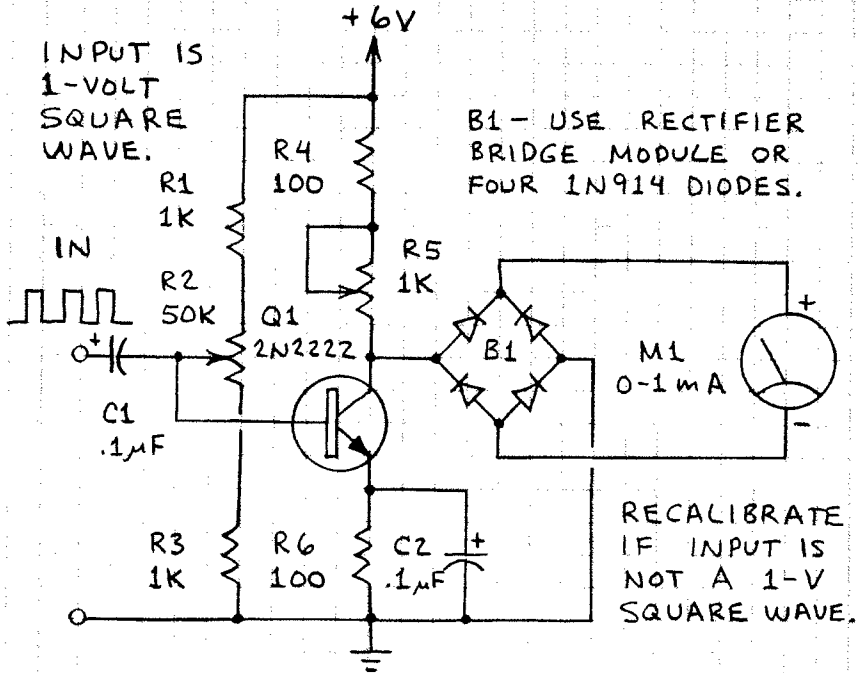

THIS CIRCUIT IS SUITABLE FOR SPECIFIC ROLES RATHER THAN GENERAL FREQUENCY MEASUREMENTS. TO CALIBRATE FOR 0-1 KHZ RANGE:

1. SET R2 AND R5 AT MID POINTS.
2. APPLY 1KHZ, 1VOLT SQUARE WAVE AT INPUT.
3. ADJUST R2 UNTIL M1 = 1mA.
4. REMOVE 1KHZ SIGNAL.
5. ADJUST R3 UNTIL M1 = 0.
6. REAPPLY 1KHZ SIGNAL.
7. ADJUST R2 UNTIL M1 = 1mA.

TYPICAL RESULTS:

SIGNAL (Hz)	M1 (mA)
0	.02
100	.1
200	.24
300	.34
400	.44
500	.55
600	.65
700	.77
800	.85
900	.95
1000	1.00



# PULSE GENERATOR

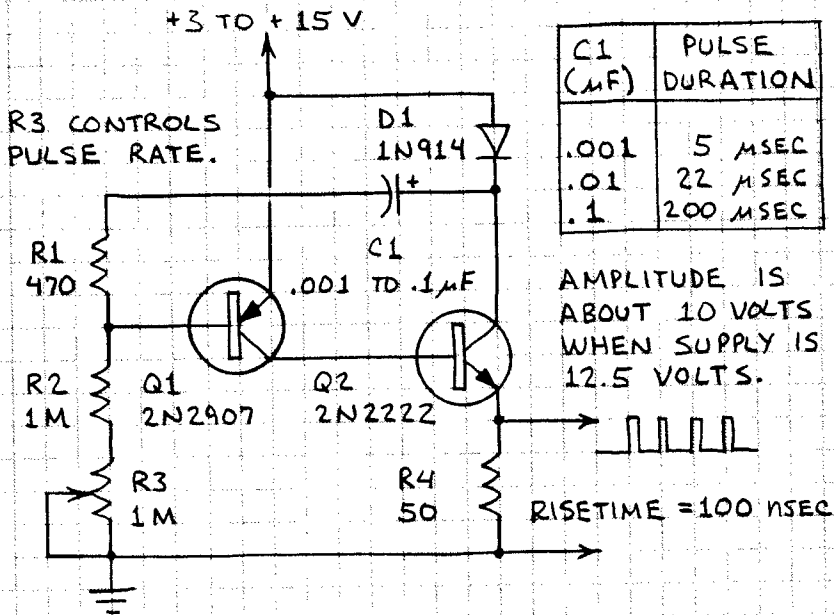

# DC METER AMPLIFIER

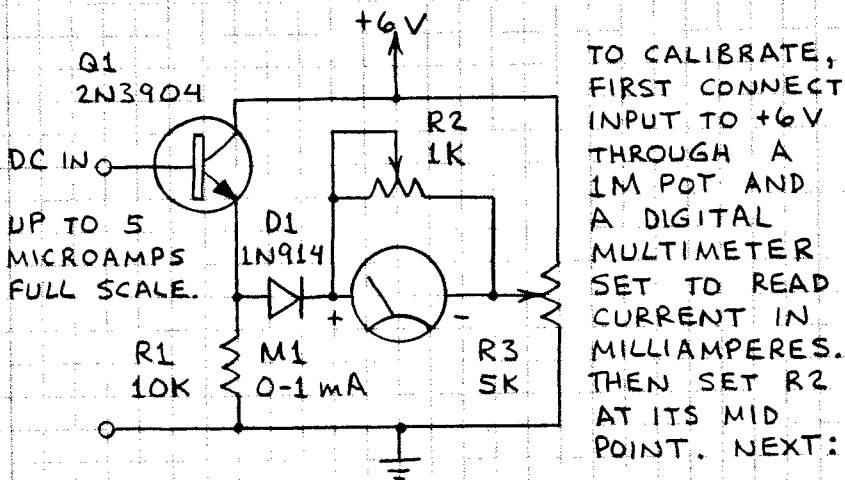

1. SET 1M POT FOR DESIRED CURRENT.
2. ADJUST R3 UNTIL M1 INDICATES 1 mA.
3. REPEAT STEPS 1 AND 2.
4. ADJUST R2 UNTIL M1 INDICATES 1 mA.

# RESISTOR-TRANSISTOR LOGIC

THESE LOGIC CIRCUITS CAN BE USED TO TEACH BASICS OF DIGITAL LOGIC AND IN PRACTICAL APPLICATIONS.

## OR GATE

0 = GROUND  
1 = +6V

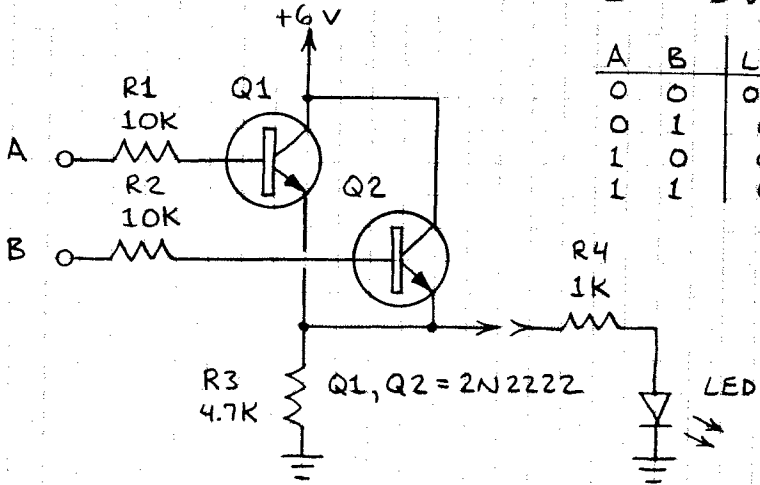

A	B	LED
0	0	OFF
0	1	ON
1	0	ON
1	1	ON

## NOR GATE

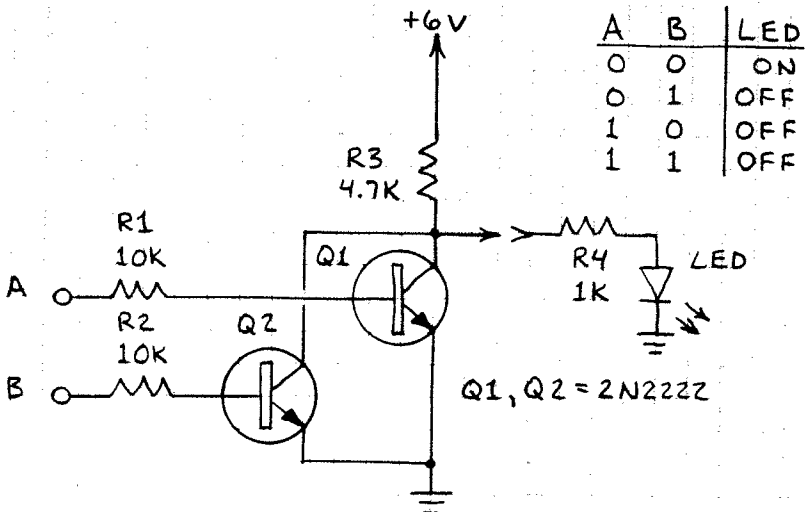

A	B	LED
0	0	ON
0	1	OFF
1	0	OFF
1	1	OFF

# AND GATE

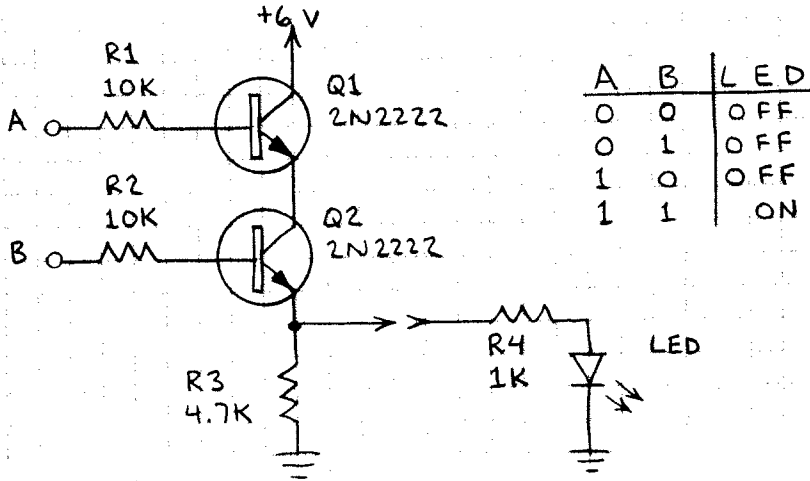

# NAND GATE

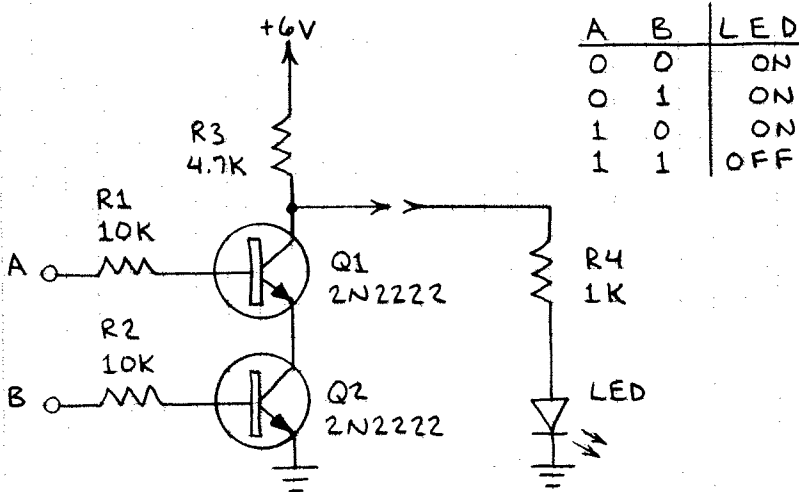

# INVERTER

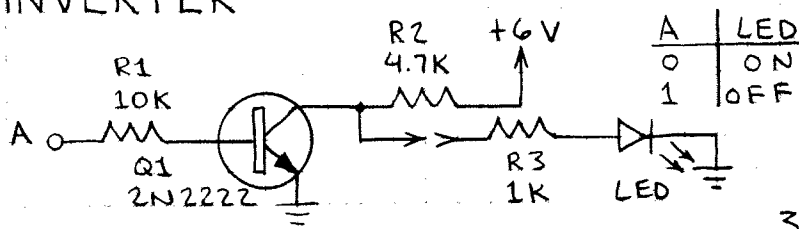

# JUNCTION FETS

A JUNCTION FIELD-EFFECT TRANSISTOR (FET) IS A 3-TERMINAL SEMICONDUCTOR DEVICE IN WHICH A SMALL VOLTAGE AT ONE TERMINAL CAN CONTROL A CURRENT FLOWING BETWEEN THE SECOND AND THIRD TERMINAL. FETS CAN FUNCTION AS BOTH AMPLIFIERS AND SWITCHES. THE PRINCIPLE ADVANTAGE OF THE FET IS ITS VERY HIGH INPUT (GATE) IMPEDANCE. FETS ARE CLASSIFIED AS EITHER N- OR P-CHANNEL ACCORDING TO THE DOPING OF THE CURRENT-CARRYING CHANNEL REGION.

## BASIC FET SWITCHES (N-FET)

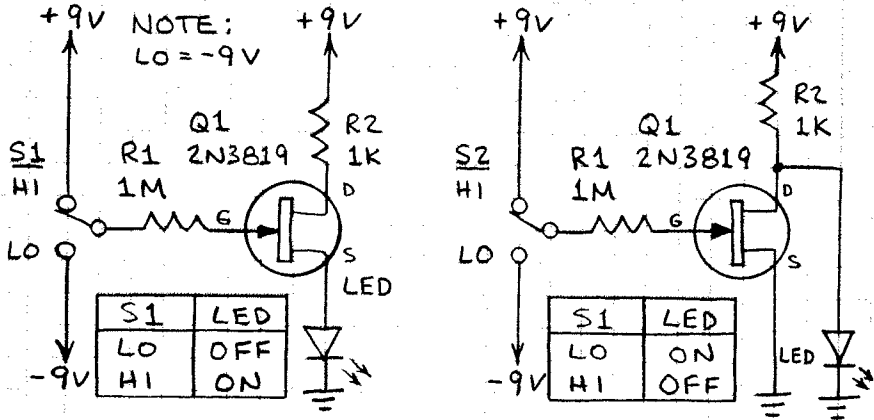

## BASIC FET AMPLIFIER (N-FET)

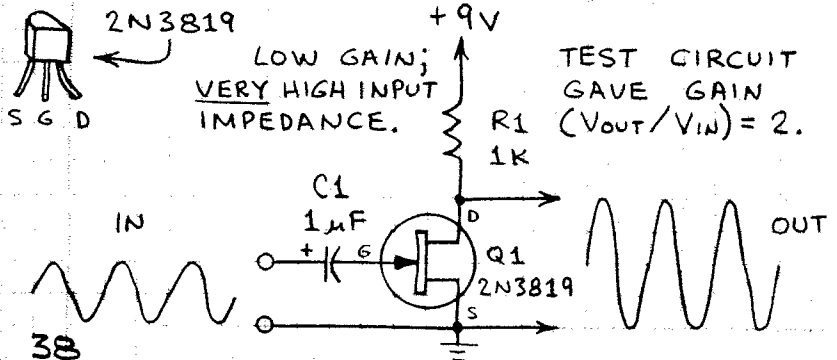

# HI-Z MICROPHONE PREAMPLIFIER

USE TO COUPLE HIGH-IMPEDANCE CRYSTAL-TYPE MICROPHONES TO AMPLIFIER.

R2 IS GAIN CONTROL.

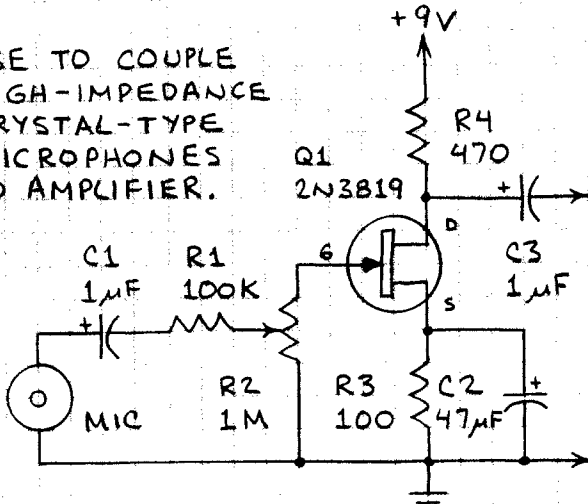

TO AMPLIFIER

KEEP LEADS TO MICROPHONE SHORT OR USE SHIELDED CABLE.

# HI-Z AUDIO MIXER

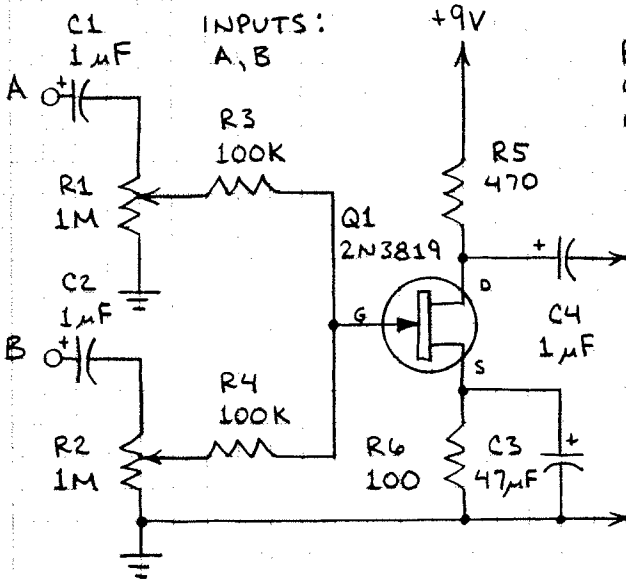

R1 AND R2 CONTROL GAIN FOR INPUTS A AND B.

TO AMPLIFIER

USE TO COMBINE SIGNALS FROM TWO OR MORE MICROPHONES, PREAMPLIFIERS, ETC.

# POWER MOSFETS

A METAL-OXIDE-SEMICONDUCTOR FET (CMOSFET) HAS A GATE WHICH IS INSULATED FROM THE CHANNEL BY A VERY THIN GLASSY OXIDE. THEREFORE THE INPUT IMPEDANCE OF THE MOSFET IS CONSIDERABLY HIGHER THAN THAT OF THE STANDARD FET. POWER MOSFETS HAVE A VERY LOW RESISTANCE CHANNEL. THEREFORE THEY CAN CONTROL MUCH MORE CURRENT THAN FETS.

## ON-AFTER-DELAY TIMER

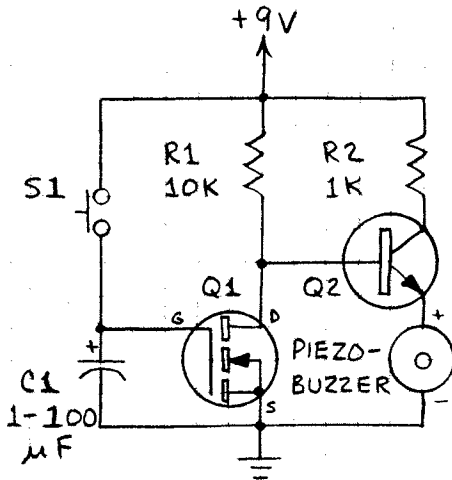

PRESS S1 TO CHARGE C1. THE PIEZO-BUZZER EMITS TONE AFTER C1 SELF DISCHARGES. LARGE VALUES FOR C1 INCREASE THE DELAY. PLACE LARGE VALUE RESISTOR ACROSS C1 TO REDUCE DELAY. Q1-POWER MOSFET. Q2-2N2222.

## ON-DURING-DELAY TIMER

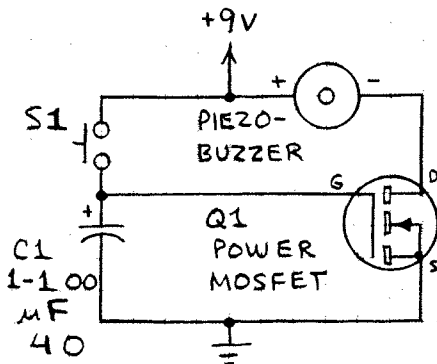

PRESS S1 TO CHARGE C1. THE PIEZO-BUZZER EMITS TONE UNTIL C1 SELF DISCHARGES. INCREASE C1 TO INCREASE DELAY. RESISTOR ACROSS C1 WILL REDUCE DELAY.

# HI-Z SPEAKER AMPLIFIER

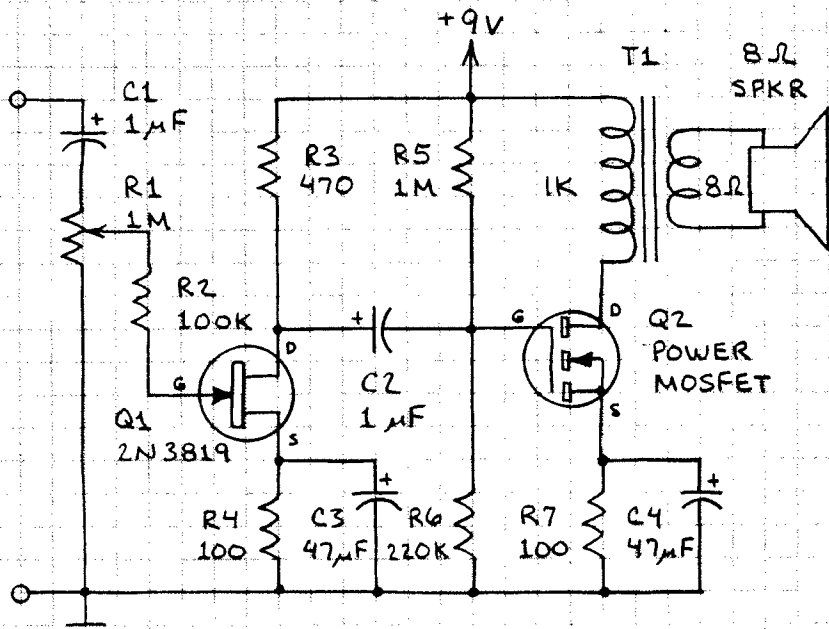

R1 CONTROLS GAIN. INPUT CAN BE HIGH-IMPEDANCE MICROPHONE, RADIO, ETC.

# DUAL LED FLASHER

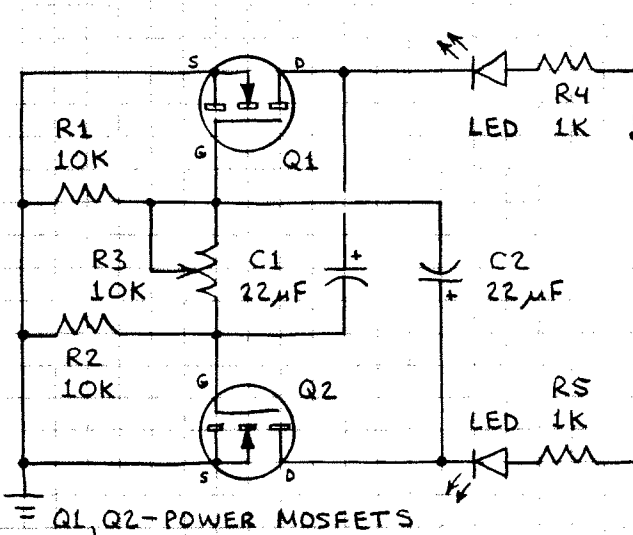

LEDS FLASH ALTERNATELY. R3 CONTROLS FLASH RATE. QUICKLY SHORT C1 OR C2 IF CIRCUIT FAILS TO FLASH.

Q1, Q2 - POWER MOSFETS

# UNIUNION TRANSISTORS

THE UNIUNION TRANSISTOR (UJT) IS A VOLTAGE-CONTROLLED SWITCH AND NOT A TRUE TRANSISTOR. THE UJT IS WELL SUITED FOR MANY OSCILLATOR APPLICATIONS.

## BASIC UJT OSCILLATOR

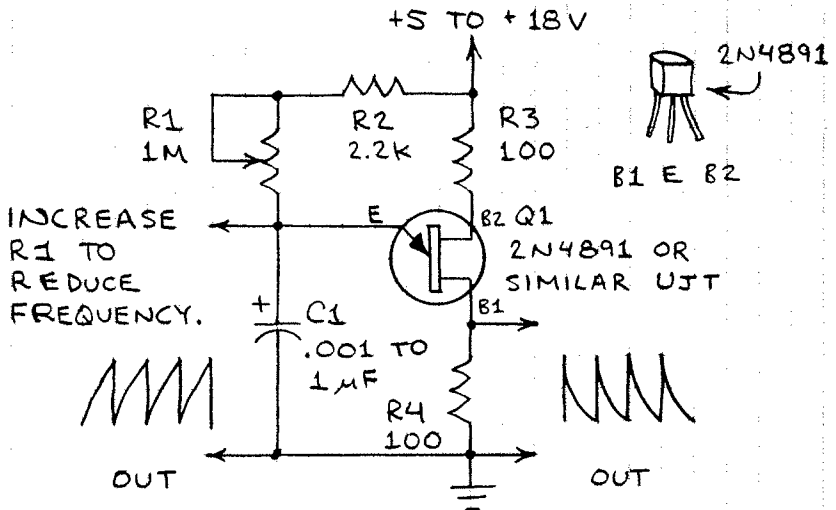

## LOW-VOLTAGE INDICATOR

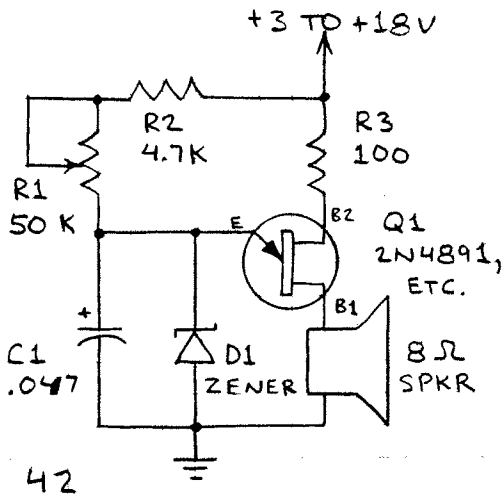

SOUNDS WARNING TONE WHEN THE SUPPLY VOLTAGE FALLS BELOW D1'S TURN-ON VOLTAGE. SELECT D1 FOR DESIRED VOLTAGE. OK TO USE A SINGLE FIXED CAPACITOR FOR R1 AND R2 (4.7K GIVES 2.8 KHZ).



# SOUND-EFFECTS GENERATOR

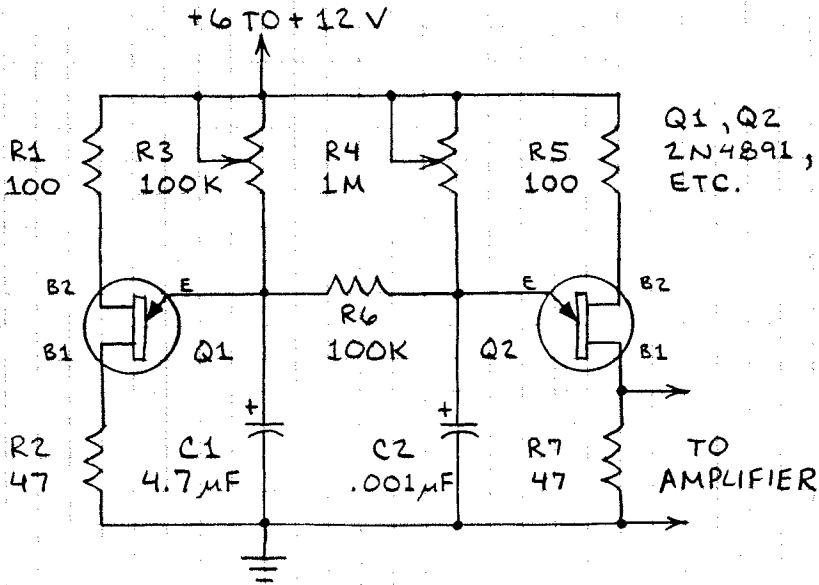

THIS CIRCUIT GENERATES CHIRPS HAVING A FREQUENCY CONTROLLED BY R4. R3 CONTROLS RATE.

# 1-MINUTE TIMER

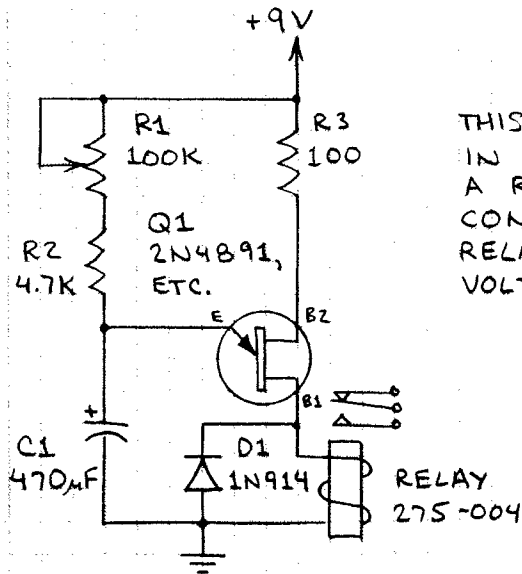

THIS CIRCUIT PULLS IN THE RELAY AT A REPETITIVE CYCLE CONTROLLED BY R1. RELAY MUST BE LOW-VOLTAGE TYPE.

R1+R2 (OHMS)	DELAY (SEC.)
10K	7
15K	10
22K	12
47K	27
100K	68

# PIEZOELECTRIC BUZZERS

PIEZO BUZZERS DELIVER EAR-PIERCING TONE AT LOW DRIVE CURRENT AND VOLTAGE.

**CAUTION:** USE EAR PROTECTORS WHEN EXPERIMENTING WITH PIEZO BUZZERS AT CLOSE RANGE FOR MORE THAN BRIEF INTERVALS.

## BELL

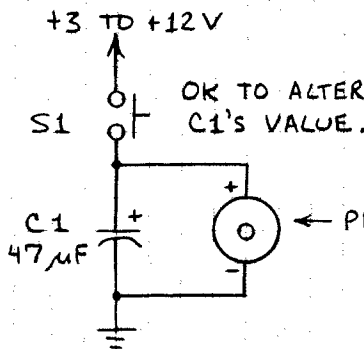

## VOLUME CONTROL

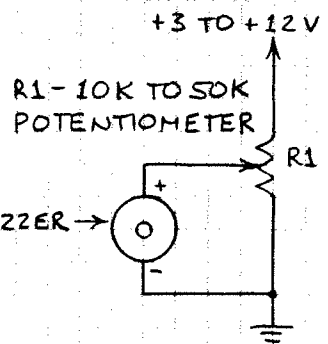

PRESS AND RELEASE S1 TO SIMULATE BELL.

R1 CONTROLS VOLUME.

# LOGIC INTERFACES

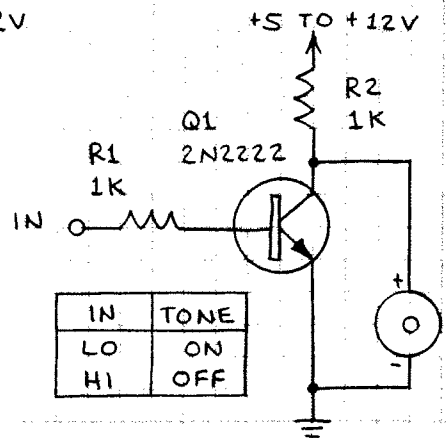
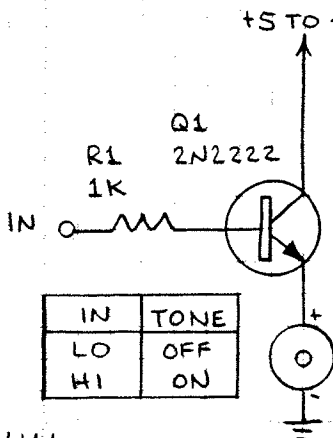

# PIEZO-ELEMENT DRIVERS

## FIXED TONE

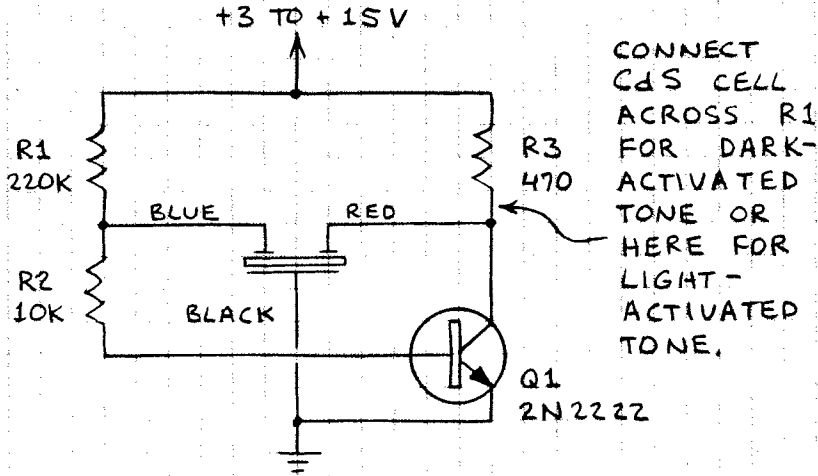

## ADJUSTABLE FREQUENCY

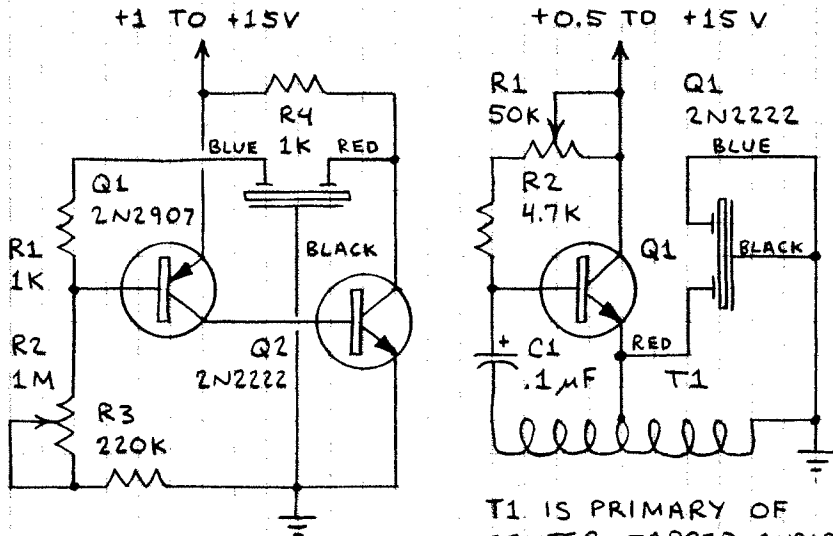

THIS CIRCUIT CAN BE EASILY MINIATURIZED. R2 CONTROLS FREQUENCY.

T1 IS PRIMARY OF CENTER-TAPPED AUDIO TRANSFORMER (RADIO SHACK 273-1380). R1 CONTROLS FREQUENCY.

# SILICON-CONTROLLED RECTIFIERS

THE SILICON-CONTROLLED RECTIFIER (SCR) IS A TRUE SOLID-STATE ON-OFF SWITCH. THE SCR IS SWITCHED ON BY A SMALL CURRENT AT ITS GATE TERMINAL. THE SCR WILL REMAIN ON UNTIL THE CURRENT FLOWING THROUGH IT FALLS BELOW A MINIMUM LEVEL ( $I_H$  OR HOLDING CURRENT).

## LATCHING PUSHBUTTON SWITCH

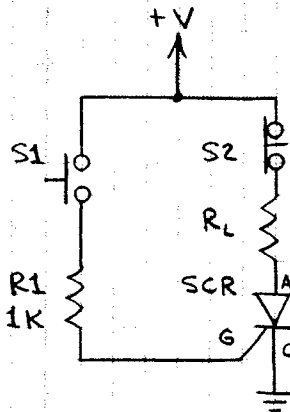

S1 - PUSH TO ACTUATE (NORMALLY OPEN)  
 S2 - PUSH TO RESET (NORMALLY CLOSED)  
 RL - LOAD (LAMP, ETC.)  
 SCR - TERMINAL PINOUTS VARY. TYPICAL:

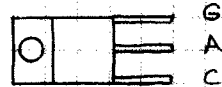

## LIGHT-ACTIVATED RELAY

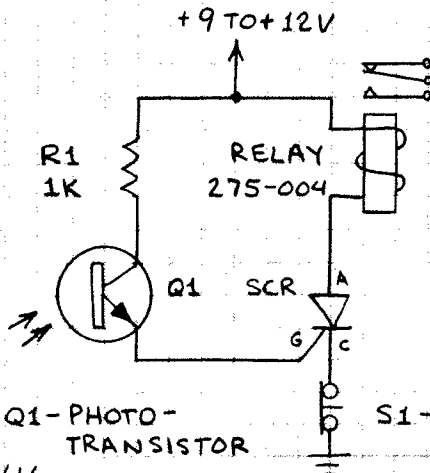

RELAY IS PULLED IN WHEN Q1 IS ILLUMINATED. RELAY REMAINS LATCHED UNTIL S1 IS PRESSED. WORKS WITH FLASHLIGHTS AND PHOTO STROBE UNITS.

Q1 - PHOTO-TRANSISTOR

S1 - PUSH TO RESET (NORMALLY CLOSED)

# RELAXATION OSCILLATOR

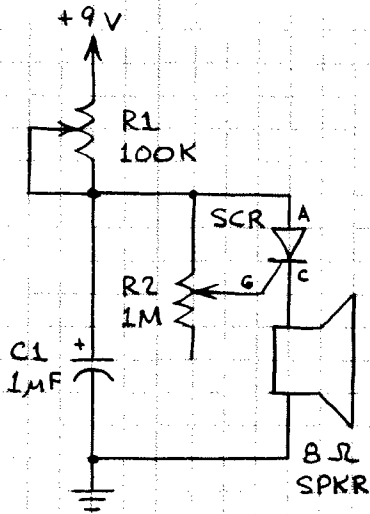

C1 IS CHARGED THROUGH R1 UNTIL ITS CHARGE IS HIGH ENOUGH TO SWITCH ON THE SCR THROUGH R2. C1 THEN DISCHARGES THROUGH THE SCR AND THE SPEAKER. R1 CONTROLS THE REPETION RATE.

NOTE: SOME SCRS REQUIRE CAREFUL ADJUSTMENT OF R2.

# DC MOTOR SPEED CONTROLLER

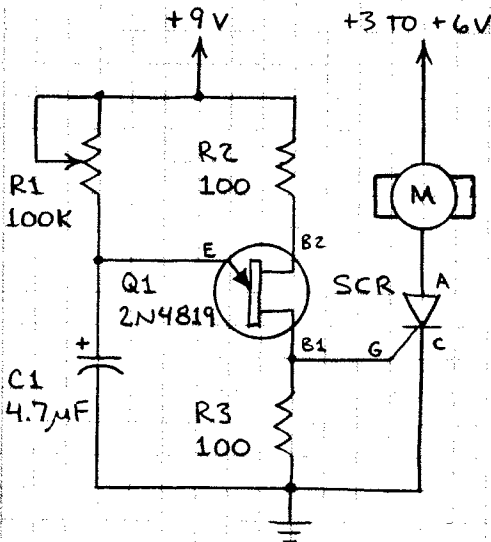

THIS CIRCUIT WILL VARY THE SPEED OF SELECTED\* DC MOTORS. R4 CONTROLS THE SPEED. AT SLOW PULSE RATES FROM THE UJT OSCILLATOR, THE MOTOR WILL ROTATE IN BURSTS. FOR BEST RESULTS, USE A SEPARATE POWER SUPPLY FOR THE MOTOR.

\*CHECK MOTOR WITH THIS CIRCUIT. IF LED FLASHES ON AND OFF WHEN SHAFT OF MOTOR IS ROTATED, IT WILL PROBABLY WORK.

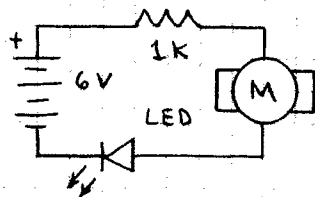

# TRIACS

THE TRIAC IS A SOLID-STATE ON-OFF SWITCH THAT CAN CONTROL ALTERNATING CURRENT. IT IS ELECTRONICALLY EQUAL TO TWO SCRS CONNECTED IN REVERSE-PARALLEL.

**WARNING:** TRIACS ARE DESIGNED FOR AC OPERATION. USE COMMON SENSE SAFETY PRECAUTIONS WHEN WORKING WITH CIRCUITS THAT USE HOUSEHOLD LINE CURRENT. ALL CONNECTIONS MUST BE WELL INSULATED. NEVER WORK ON AN AC LINE POWERED CIRCUIT WHEN THE POWER CORD PLUG IS INSERTED IN A WALL SOCKET.

## TRIAC SWITCH BUFFER

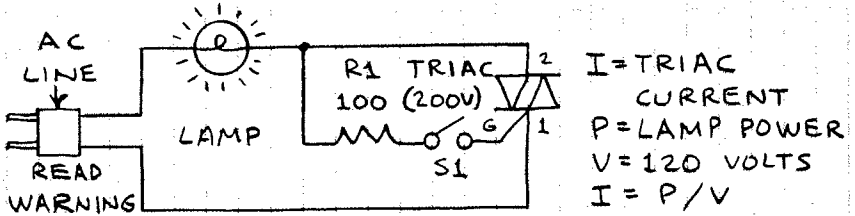

## LAMP DIMMER

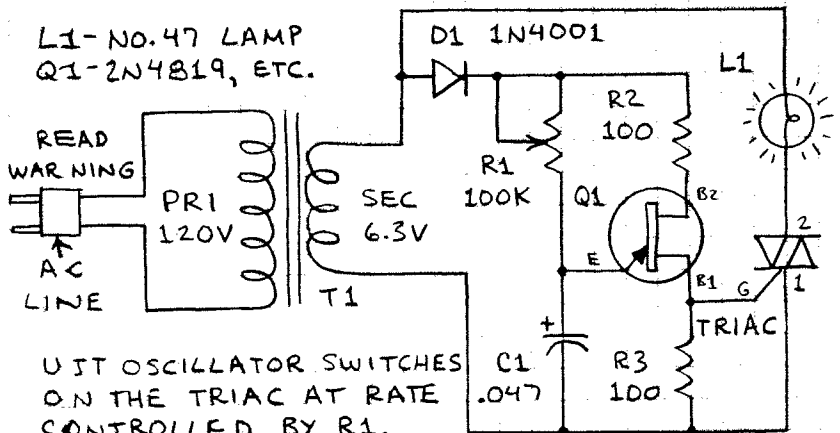



---

**Radio Shack**

A Division of Tandy Corporation  
Fort Worth, TX 76102

PRINTED IN U.S.A.

62-5013



0 40293 10894 6

---